



OZARKS
TRANSPORTATION
ORGANIZATION

A METROPOLITAN PLANNING ORGANIZATION

TITLE VI/ADA PROGRAM

2024

**TITLE VI OF THE
CIVIL RIGHTS ACT
OF 1964**

OZARKSTRANSPORTATION.ORG

Ozarks Transportation Organization

Resolution # 2024-05

**RESOLUTION OF THE BOARD OF DIRECTORS
OF
Ozarks Transportation Organization
a Missouri Nonprofit Corporation**

May 16, 2024

RESOLUTION ADOPTING THE TITLE VI/ADA PROGRAM

The members of the Board of Directors (the “**Board**”) of Ozarks Transportation Organization Inc., a Missouri nonprofit corporation (the “**Organization**”), acting pursuant to Mo. Ann. Stat. § 355.246 (West) (the “**Act**”), do hereby consent to the adoption of the following resolution:

WHEREAS, the U.S. Department of Transportation (DOT) requires that all recipients of federal funding develop and implement a program that ensures that the federal-aid recipient is implementing programs and activities in a nondiscriminatory manner and in compliance with the Civil Rights Act of 1964 and other statutes, regulations, executive orders, and guidance that mandate nondiscrimination;

WHEREAS, the Federal Transit Administration (FTA) has issued guidance that describes the requirements for and content of these nondiscrimination programs known as Title VI Programs, which includes, in part, that a federal-aid recipient’s Title VI Program: (1) be updated every three years, (2) include a signed Title VI Assurance, and (3) be approved by the recipient’s governing body;

WHEREAS, Ozarks Transportation Organization is the Metropolitan Planning Organization Springfield Metropolitan Area and is a recipient of federal funding, including DOT funding;

WHEREAS, Ozarks Transportation Organization has completed an update of its Title VI/ADA Program;

NOW, THEREFORE, BE IT RESOLVED, by the Ozarks Transportation Board of Directors:

1. The 2024 Title VI/ADA Program is approved and adopted.
2. The Limited English Proficiency Plan is approved.
3. The Executive Director or his designee is authorized to execute the Standard DOT Assurances and Policy of Nondiscrimination.
4. The Executive Director or his designee is authorized to make minor changes to the Title VI/ADA Program that are necessary to keep the documents up-to-date (i.e. update contact information, fix broken URLs, etc.) and in compliance with any new or revised state or federal requirements. This authorization is limited to the three year period between the date that the 2024 Title VI Program is accepted by FTA and the date that the next Title VI Program update is due to DOT and presented to the Board of Directors for approval.

The above resolution is hereby Adopted on this 16th day of May 2024.

DocuSigned by:

AFF79292E005476...

Mr. Derek Lee

Chair, Board of Directors

DocuSigned by:

Attest:
ABBFEBEDDB089400...

Ms. Martha Smartt
Secretary, Board of Directors

Contents

Introduction	3
Environmental Justice.....	3
Limited English Proficiency (LEP).....	3
Persons with a Disability.....	3
The Ozarks Transportation Organization	4
Title VI Coordinator.....	4
Title VI - FHWA Requirements (Exclusive of Common Requirements in FTA Circular 4702.1B)	7
Policy of Nondiscrimination	7
Primary Program Area Descriptions.....	7
Standard DOT Assurances.....	7
Title VI - General Requirements: FTA Circular 4702.1B (Chapter III).....	7
Title VI Notice to the Public, including a list of locations where the notice is posted.....	8
Title VI Complaint Procedures	8
Title VI Complaint Form and Policy	11
List of transit-related Title VI investigations, complaints, and lawsuits.....	11
Public Participation Plan.....	12
Language Assistance Plan.....	12
Boards and Committees.....	15
Sub-Recipient Monitoring.....	17
Title VI Equity Facility Analysis.....	17
Title VI - Requirements for MPOs: FTA Circular 4702.1B (Chapter VI)	17
Demographic profile of the metropolitan area.....	17
Fixed Route Transit Requirements	24
Mobility Needs of Minority Populations	24
Distribution of State and Federal Funds for Public Transportation Projects	24
Analysis of Disparate Impacts.....	26
Nondiscriminatory Passthrough of FTA financial assistance (if requested).....	26
Nondiscrimination in subrecipient assistance (if requested)	27
ADA - Program Access.....	27
Public Meetings.....	27
Electronic Documents.....	27
Website.....	28

Implementation 28

Appendix A: Standard DOT Assurances

Appendix B: Title VI/ADA Complaint Procedures and Form, including Title VI Public Notice

Appendix C: Title VI/ Complaint Procedures and Form in Spanish, including Title VI Public Notice

Appendix D: ADA Public Notice

Appendix E: Public Participation Plan

Appendix F: Limited English Proficiency Plan

Appendix G: Letter to Owner of Chesterfield Lofts Concerning ADA Issues

Appendix H: Accessible Formatting for Word

Appendix I: Title VI/ADA/LEP Implementation Guide

Appendix J: OTO Title VI/ADA/LEPP Resources

This report was prepared in cooperation with the USDOT, including FHWA and FTA, as well as the Missouri Department of Transportation. The opinions, findings, and conclusions expressed in this publication are those of the authors and not necessarily those of the Missouri Highways and Transportation Commission, the Federal Highway Administration, or the Federal Transit Administration.

Introduction

Title VI of the 1964 Civil Rights Act, 42 U.S.C. 2000d provides that: *“No person in the United States shall, on the ground of race, color, or national origin, be excluded from participation in, be denied the benefits of, or be subjected to discrimination under any program or activity receiving Federal financial assistance.”* The broader application of nondiscrimination law is found in other statutes, executive orders, and regulations, which provide additional protections based on age, sex, religion, and disability, including the 1987 Civil Rights Restoration Act, which extended nondiscrimination coverage to all programs and activities of federal-aid recipients, subrecipients, and contractors, including those that are not federally-funded (see Appendix B– Applicable-Nondiscrimination Authorities).

The Ozarks Transportation Organization (OTO) is a recipient of Federal financial assistance from the Missouri Department of Transportation (MoDOT) and the United States Department of Transportation (USDOT), receiving Federal Transit Administration (FTA) and Federal Highway Administration (FHWA) funds through MoDOT. As the primary recipient of USDOT funds in Missouri, MoDOT’s comprehensive Title VI Nondiscrimination Program includes compliance oversight and technical assistance responsibilities towards its subrecipients and those subrecipients must use federal and state funds in a nondiscriminatory manner.

The Ozarks Transportation Organization (OTO) establishes this Title VI Nondiscrimination Plan for the purpose of complying with Title VI of the Civil Rights Act of 1964, as required by FTA Circular 4702.1B, of the FTA Certifications and Assurances. This document details the nondiscrimination program, policies, and practices administered by this organization, and will be updated every three years as required by FTA regulations.

Environmental Justice

In 1994, Executive Order 12898, was signed into law requiring federal agencies to make environmental justice part of their mission by identifying and addressing, disproportionately high and adverse effects of its programs, policies, and activities on minority populations and low-income populations. FTA Circular 4703.1 provides guidance for recipients of FTA financial assistance to incorporate Environmental Justice into plans and projects that receive FTA funding. Currently, the OTO includes Environmental Justice as part of the Long-Range Transportation Plan (LRTP) and as part of the weighting factor in the annual Transportation Improvement Program (TIP).

Limited English Proficiency (LEP)

On August 11, 2000, Executive Order 13166 was signed into law by President William Jefferson Clinton. This executive order required improved access to service for LEP persons, and gave Title VI (discrimination) protection to LEP persons. In 2012, the Federal Transit Authority (FTA) released their guidelines and requirements for recipients of FTA financial assistance (FTA C 4702.1). This required MPOs to have an LEP plan, which identifies the LEP populations which might need improved access to the planning process, the methods to identify LEP individuals at public meetings, and identifies available language services.

Persons with a Disability

The Americans with Disabilities Act of 1991 and Section 504 of the Rehabilitation Act of 1973 prohibits discrimination based on a disability by public and private sector parties. As a federally funded entity, the

OTO must abide by Title II of the Americans with Disabilities Act. Title II of the Americans with Disabilities Act requires that publicly funded entities give people with disabilities equal access to benefits of the programs, services and activities that may be offered. The OTO's small size exempts it from the requirements to have a current self-assessment and transition plan, but efforts have been made to complete a Program Access Plan to ensure the OTO meetings and its website are accessible and comply with the Americans with Disabilities Act and Section 504. OTO meetings for the Board of Directors, Technical Planning Committee, Local Coordinating Board of Transportation, and Bicycle and Pedestrian Advisory Board are open to the public, and conducted in locations that offer ease of access to those with disabilities. Efforts are also underway to improve the accessibility of the OTO website by including descriptions of all images, use of hierarchical coding, and text-based versions of plans and policies.

The Ozarks Transportation Organization

The Ozarks Transportation Organization (OTO) is the federally designated metropolitan planning organization (MPO) that serves as a forum for cooperative transportation decision-making by state and local governments, as well as regional transportation and planning agencies for the Springfield urbanized area. MPOs are charged with maintaining and conducting a "continuing, cooperative, and comprehensive" regional transportation planning and project programming process for the MPO's study area. The study area is defined as the area projected to become urbanized within the next 20 years.

The MPO includes local elected and appointed officials from Christian and Greene Counties, as well as the Cities of Battlefield, Nixa, Ozark, Republic, Springfield, Strafford, and Willard. It also includes technical staffs from the Missouri Department of Transportation, Federal Highway Administration, Federal Transit Administration, and the Federal Aviation Administration. Staff members from local governments and area transportation agencies serve on the OTO's Technical Planning Committee which provides technical review, comments, and recommendations on draft plans, programs, studies, and issues.

Title VI Coordinator

The individual below has been designated as the Title VI Coordinator for the Ozarks Transportation Organization, and is empowered with sufficient authority and responsibility to implement the Title VI Nondiscrimination Program:

David Knaut
Ozarks Transportation Organization
2208 West Chesterfield Blvd., Suite 101
Springfield, MO 65807
417-865-3047 X107

The Coordinator's Responsibilities include:

- Collect Data for the Title VI program, including, but not limited to, demographic data.
- Develop yearly reports for FHWA review of the Title VI program.
- Update relevant Title VI documents.

- Circulating Title VI information internally and to the general public.
- Presenting Title VI-related information to the BOD and TPC boards for input and approval.
- Ensuring that the Title VI program is reasonably implemented and provides opportunities for the public to participate in the OTO activities in a nondiscriminatory manner.
- Implementing measures for prompt processing (receiving, logging, investigating and/or forwarding) of discrimination complaints.
- Swiftly resolving areas of deficiency to ensure compliance with Title VI nondiscrimination requirements.
- Attend any type of available training relevant to civil rights, Title VI, LEP, ADA etc. (when possible) offered by MoDOT or another regulatory agency.

The OTO responsibilities include:

- Title VI training will be administrated during new hire orientation and with annual staff training.
- Encourage all Employees to participate in Title VI professional development training opportunities.

Figure 1 MPO Study Area

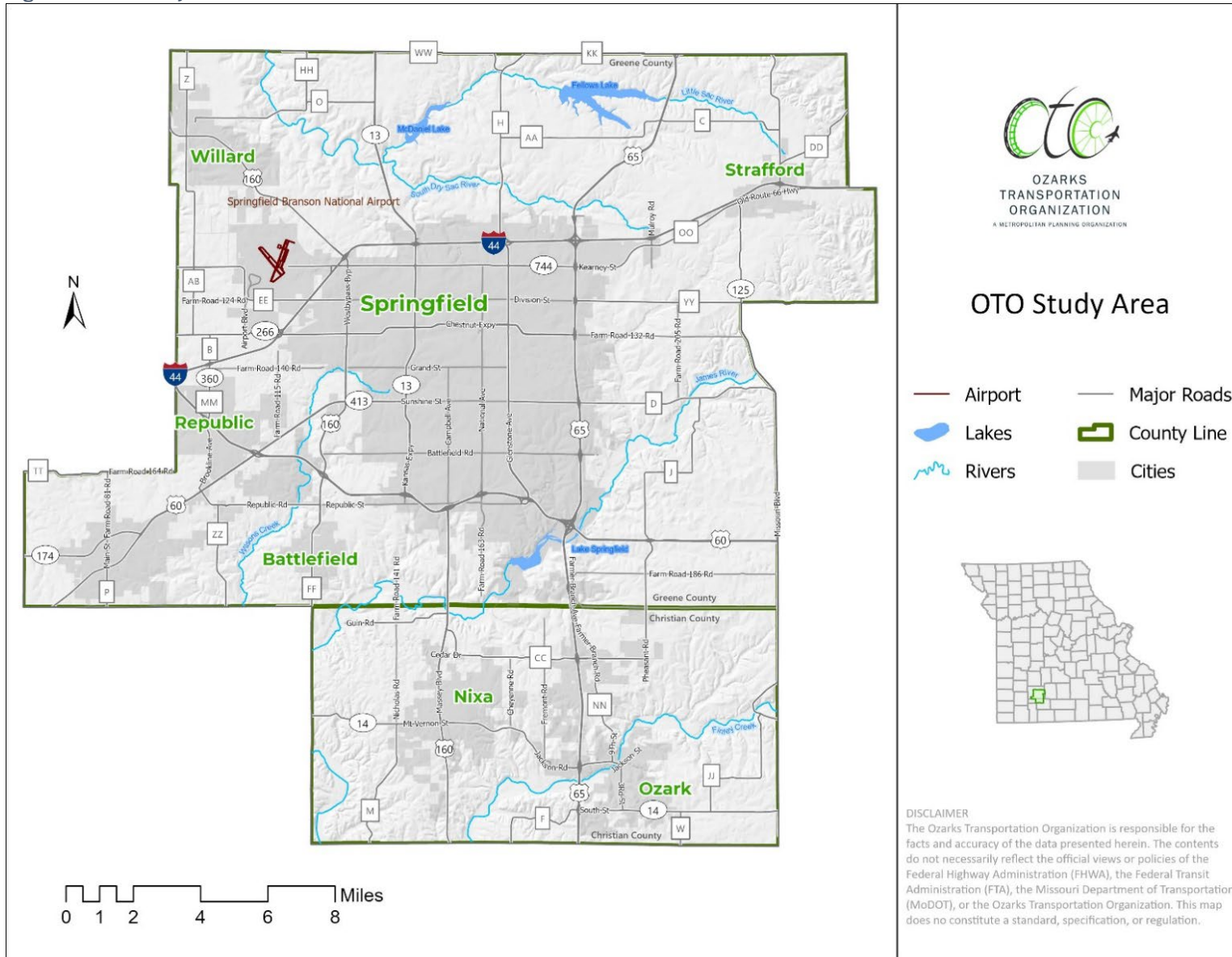

Title VI - FHWA Requirements (Exclusive of Common Requirements in FTA Circular 4702.1B)

Title VI requirements established by the Federal Highway Administration are contained in 20 CFR Part 200. Many FHWA requirements are similar to requirements outlined in FTA Circular 4702.1B. Requirements deemed exclusive to FHWA by OTO staff are addressed in this section. The remaining requirements are addressed through compliance with FTA Circular 4702.1B.

Policy of Nondiscrimination

The Ozarks Transportation Organization (OTO) assures that no person shall on the grounds of race, color, national origin, sex, age, disability or income as provided by Title VI of the Civil Rights Act of 1964 and related authorities, be excluded from participation in, be denied the benefits of, or be otherwise subjected to discrimination under any OTO sponsored program or activity. The OTO further assures every effort will be made to ensure non-discrimination in all of its programs and activities, whether those programs and activities are federally funded or not.

OTO Director

Date

5/20/24

Primary Program Area Descriptions

The OTO's program area is transportation planning. In conducting its transportation planning activities, the OTO seeks input from local governments and members of the general public, analyzes data for purposes of identifying transportation needs, prioritizes projects using data-driven metrics, and programs projects in its Transportation Improvement Program. As described in the following sections, the OTO's Public Participation Plan guides outreach efforts to minority and LEP individuals. Policies include adding underserved populations to interested parties mailing lists, locating meetings at transit accessible locations, and ensuring ADA compliant meeting facilities are used. Additional ADA discussion can be found in the ADA Program Access Section. An EJ based scoring criteria is included in the prioritization scoring criteria. Finally, key draft documents, including the long-range transportation plan and the transportation improvement program, are made available for public comment at key locations in minority communities.

Standard DOT Assurances

A signed copy of the standard DOT Assurances can be found in Appendix A.

Title VI - General Requirements: FTA Circular 4702.1B (Chapter III)

General Requirements (Chapter III) All recipients must submit:

- Title VI Notice to the Public, including a list of locations where the notice is posted
- Title VI Complaint Procedures (i.e., instructions to the public regarding how to file a Title VI discrimination complaint)

- Title VI Complaint Form
- List of transit-related Title VI investigations, complaints, and lawsuits
- Public Participation Plan, including information about outreach methods to engage minority and limited English proficient populations (LEP), as well as a summary of outreach efforts made since the last Title VI Program submission
- Language Assistance Plan for providing language assistance to persons with Limited English Proficiency (LEP), based on the DOT LEP Guidance
- A table depicting the membership of non-elected committees and councils, the membership of which is selected by the recipient, broken down by race, and a description of the process the agency uses to encourage the participation of minorities on such committees
- Primary recipients shall include a description of how the agency monitors its subrecipients for compliance with Title VI, and a schedule of subrecipient Title VI Program submissions
- A Title VI equity analysis if the recipient has constructed a facility, such as a vehicle storage facility, maintenance facility, operation center, etc.
- A copy of board meeting minutes, resolution, or other appropriate documentation showing the board of directors or appropriate governing entity or official(s) responsible for policy decisions reviewed and approved the Title VI Program. For State DOT's, the appropriate governing entity is the State's Secretary of Transportation or equivalent. The approval must occur prior to submission to FTA
- Additional information as specified in chapters IV, V, and VI, depending on whether the recipient is a transit provider, a State, or a planning entity

Title VI Notice to the Public, including a list of locations where the notice is posted

In compliance with, 49 CFR Section 21.9(d), the Ozarks Transportation Organization posts a "Notice to Beneficiaries under Title VI" on the OTO public bulletin board located at the entrance of the OTO office, on board agendas, and on the OTO website. This notice gives public notification and guidance for OTO's complaint procedure and complaint form. The OTO's Title VI Public Notice:

OTO fully complies with Title VI of the Civil Rights Act of 1964 and related statutes and regulations in all programs and activities. For more information or to obtain a Title VI Complaint Form, see <https://www.ozarkstransportation.org/our-resources/civil-rights> or call (417) 865-3042.

Title VI Complaint Procedures

General steps of the OTO's complaint process:

1. Alleged act of discrimination
2. Formal complaint received and logged by OTO
3. Formal complaint review by OTO

4. OTO letter of response issued
5. Corrective action or closure letter issued

Who may file a complaint: Any person who believes that the Ozarks Transportation Organization (OTO) has discriminated against them on the basis of race, color, national origin, age, disability, religion, sex or English proficiency, then that person may file a written complaint by following the Title VI complaint procedure.

Formal complaint received and logged by OTO: The Ozarks Transportation Organization has a Title VI Complaint Procedure, which outlines a process for local disposition of Title VI complaints and is consistent with guidelines found in Chapter VII of the Federal Transit Administration Circular 4702.1B, dated October 1, 2012. The OTO does not discriminate on the basis of race, color, national origin, age, disability, religion, sex, or English proficiency and makes available a Title VI complaint procedure and guidance for formal complaints against the OTO.

Submission of a civil rights complaint should be filed immediately following the alleged act of discrimination against the complainant. Complaints must be filed with the OTO within 180 calendar days of the date the complainant believes the discrimination occurred. Complaints should be mailed to:

David Knaut
Title VI Coordinator
Ozarks Transportation Organization
2208 West Chesterfield Blvd., Suite 101
Springfield, MO 65807

Formal complaint reviewed and investigated by OTO or FHWA: Once the complaint is received, the OTO will review it to determine which agency has jurisdiction. The complainant will receive an acknowledgement letter informing which agency will investigate the complaint. If the complaint is related to a program or service through the Federal Highway Administration (FHWA), the complaint will be directly forwarded to Missouri Department of Transportation (MoDOT), which should forward the complaint to the State's FHWA Division Office, which should forward the complaint to the FHWA Headquarters Office of Civil Rights (HCR). HCR is responsible for conducting review and investigation of all FHWA-related complaints following FHWA guidance. More information on FHWA procedures and responsibilities can be found on FHWA's webpage: <https://highways.dot.gov/civil-rights/title-vi-civil-rights-act-1964-and-additional-nondiscrimination-requirements>. As outlined in the Collaboration with Other Agencies section, OTO will notify FHWA of all complaints received.

For non-FHWA related complaints, OTO will generally complete an investigation within 90 days from receipt of a completed complaint form. If it is determined that more time is needed to review or investigate the complaint, the OTO Executive Director will notify the complainant with an estimated time frame for completing the review.

The Title VI Coordinator shall meet with the complainant within 45 calendar days after receiving the official complaint to clarify any part of the official complaint, if needed. If additional information is needed, OTO will notify complainant via letter and the complainant has 10 business days from the date of letter to send requested information to the Title VI Coordinator. If the complainant fails to contact or

provide additional requested information within 10 business days, OTO can administratively close the case. A case can also be administratively closed if the complainant no longer wishes to pursue their case.

Corrective action or closure letter issued: If the Title VI Coordinator and the Executive Director concur there was no Title VI violation, a letter of closure will be issued summarizing the allegations and stating that there were no Title VI violations or, if a violation did occur then a letter of finding will be issued stating the corrective action. Either response will be notification that the complaint has been resolved and closed.

The complainant may request reconsideration in writing to the OTO Executive Director no later than 10 days of an issued response letter from the OTO. The Executive Director will accept or reject the request for reconsideration within 10 calendar days and notify the complainant of the decision.

The complainant may further appeal in writing a denied decision no later than 10 calendar days after an issued notification. All information will be presented to the OTO Board of Directors to decide whether they agree or disagree with the decision.

A dissatisfied complainant may also file a complaint with the State of Missouri Department of Transportation, Federal Highway Administration, or Federal Transit Administration no later than 180 days after the alleged date of discrimination.

Contact Information for MoDOT, FHWA, and FTA Civil Rights Offices		
MoDOT External Civil Rights Division Attn: Title VI Program Coordinator 1617 Missouri Blvd P.O. Box 270 Jefferson City, MO 65102	Federal Transit Administration Office of Civil Rights Attention: Complaint Team East Building, 5th Floor - TCR 1200 New Jersey Ave., SE Washington, DC 20590	Federal Highway Administration Office of Civil Rights 1200 New Jersey Avenue, SE 8 th Floor E81-105 Washington, DC 20590

Collaboration with Other Agencies: In the event a formal complaint is received, the OTO will prepare a written statement within 10 working days describing the complaint. The OTO will use the written statement to notify the agencies listed below and any local agencies affected. Up-to-date information will be uniformly shared with each agency during the complaint review process for non-FHWA related complaints. The OTO may request input or guidance from any of these agencies, if needed. Agencies may request more or less information during the steps of collaboration.

Ozarks Transportation Organization Title VI Coordinator 2208 W Chesterfield Blvd., Suite 101 Springfield, MO 65807 Phone: 417-865-3042 Fax: 417-862-6013 dknaut@ozarkstransporation.org	Missouri Department of Transportation External Civil Rights Title VI Coordinator 1617 Missouri Blvd. PO Box 270 Jefferson City, MO 65102-0270
Federal Highway Administration Missouri Division Civil Rights Specialist 3220 W Edgewood, Suite H Jefferson City, MO 65109	Federal Transit Administration Region 7 Regional Civil Rights Officer 901 Locust St., Suite 404 Kansas City, MO 64106

Steps to collaborate with above agencies for non-FHWA related complaints:

1. Notify agencies of complaint
2. Coordinate with other agencies as appropriate in the investigation efforts
3. Provide a copy of the Letter of Response/Corrective Action/Closure Letter to agencies
4. Provide a semi-annual report of all Title VI/ADA complaints to agencies, including FHWA-related complaints

Title VI Complaint Form and Policy

The complete Title VI Complaint Form and Policy can be found in Appendix C and the OTO’s website. The compliant form and policy is also made available in Spanish.

List of transit-related Title VI investigations, complaints, and lawsuits

Table 1 shows the complaints log that the OTO maintains for Title VI compliance. There have been no complaints in the three previous reporting periods. This log is maintained separately from this Title VI document and is available upon request from the OTO’s Title VI coordinator.

Table 1: Complaints Received Log

Type			Date Received	Date Resolved	Summary Including Basis of Complaint: Race, Color, or National Origin	Status	Action(s) Taken
Complaint Date	Investigation Date	Lawsuits Date					
None	None	None			No complaints to report January-2017 through December-2017	NA	None
None	None	None			No complaints to report January-2018 through December-2018	NA	None
None	None	None			No complaints to report January-2019 through December-2019	NA	None
None	None	None			No complaints to report January-2020 through December-2020	NA	None
None	None	None			No complaints to report January-2021 through December-2021	NA	None
None	None	None			No complaints to report January-2022 through December-2022	NA	None
None	None	None			No complaints to report January-2023 through December-2023	NA	None

Public Participation Plan

The following objectives are included in the OTO's Public Participation Plan (PPP) and relate to efforts to engage minority and limited English proficient populations. The Public Participation Plan (PPP) is included in Appendix E of this document or is available through the OTO webpage (<https://www.ozarkstransportation.org/what-we-do/ppp>).

- The OTO will follow a policy of ensuring that limited English-speaking persons, persons with disabilities, and minority or low-income populations are given an opportunity to participate in the planning process.
- The OTO will strive to ensure that when conducting public meetings where matters related to transportation programs are being considered are connected to transit and meet Americans with Disabilities Act requirements.

Below are agreements listed in the OTO's PPP between the OTO and CU Transit related to engaging minority and limited English proficient populations.

- CU will assist the OTO with the public involvement process by allowing notices for public input opportunities to be placed in CU buses and facilities at no charge to the OTO.

The following points taken from the OTO's PPP relate to the OTO Contacts Database.

- The database is used for maintaining up-to-date contact information for committee membership, special interest groups, Disadvantage Business Establishments (DBE), as well as minority and low-income groups.
- The database will include (non-exhaustive):
 - Representatives of people with disabilities
 - Members of minority populations
 - Representatives of Limited English Proficiency (LEP) populations

The complete Public Participation Plan can be found in Appendix E.

Language Assistance Plan

The Language Assistance Plan is part of the Limited English Proficiency (LEP) Plan. The complete LEP plan can be found in Appendix E.

How to Identify an LEP Person Who Needs Language Assistance

Below are tools to help identify persons who may need language assistance:

- OTO staff will utilize printed material provided by CTS LanguageLink to identify a spoken language and request an over-the-phone interpreter;
- Examine records requests for language assistance from past meetings and events to anticipate the possible need for assistance at upcoming meetings;
- When OTO sponsored workshops or conferences are held, set up a sign-in sheet table, have a staff member greet and briefly speak to each attendee. To informally gauge the attendee's

ability to speak and understand English, staff will ask a question that requires a full sentence reply;

- Though language needs may not be met at the current meeting, an inventory of those needs will help staff plan for language needs at a future meeting;
- Post a notice of available language assistance in the OTO reception area.

Language Assistance Measures

Over-the-phone interpretation services are available to OTO staff for walk-in or phone-based interactions with LEP individuals. The OTO currently has a contractual relationship with CTS LanguageLink. This company provides access to interpreters for nearly any spoken language.

Relay Missouri also offers Spanish Relay service for those with hearing impairments. Relay users can type in Spanish and the conversations will be relayed in Spanish. Voice users can speak Spanish to the relay user. Spanish to English Translation is offered. Users must dial 1-800-520-7309 (TTY/ASCII/Voice).

Missouri's Office of Administration also has a list of contractors that supply LEP services including translators, in-person interpreters, phone interpreters, and sign language interpreters. These services are available through the cooperative agreements OTO has with the State of Missouri.

The OTO website may be translated into a number of different languages using Google Translate.

Outside of these measures, OTO has limited resources and will, to the extent possible, ensure LEP individuals can participate when requested.

OTO Staff Training

All OTO staff will be provided with the LEP plan and will be educated on procedures and services available. This information will also be part of the OTO staff orientation process for new hires.

Training topics include:

- Understanding the Title VI LEP responsibilities;
- What language assistance the OTO offers;
- How to access an interpreter using CTS LanguageLink;
- Documentation of language assistance requests;
- How to handle a complaint;
- The importance of educating subrecipients on the OTO's LEP program responsibilities and their obligation to provide language assistance.

Providing Notice of Available Language Service to LEP Persons

OTO will post signs that language assistance is available in public areas such as the OTO reception area or public notice bulletin board.

Outreach Techniques

- If staff knows that they will be presenting a topic that could be of potential importance to an LEP person or if staff will be hosting a meeting or a workshop in a geographic location with a known

concentration of LEP persons, staff will have meeting notices, fliers, advertisements, and agendas contain a notice, in Spanish, of language service availability with notification in advance of the meeting.

- When running a general public meeting notice, staff should insert “Si usted necesita la ayuda de un traductor, por favor comuníquese con David Knaut al (417) 865-3047, al menos 48 horas antes de la reunión,” which asks persons who need Spanish language assistance to make arrangements with OTO within two days of the meeting date.

Monitoring and Updating the LEP Plan

This plan is designed to be flexible and is one that can be easily updated. At a minimum, the OTO will follow the Title VI program update schedule for the LEP plan.

Each update should examine all plan components such as:

- How many LEP persons were encountered?
- Were their needs met?
- What is the current LEP population in the OTO region?
- Has there been a change in the types of languages where translation services are needed?
- Is there still a need for continued language assistance for previously identified OTO programs?
- Are there other programs that should be included?
- Has the OTO’s available resources, such as technology, staff, and financial costs, changed?
- Has the OTO fulfilled the goals of the LEP plan?
- Were there any complaints received?

Dissemination of the OTO Limited English Proficiency Plan

The OTO will post the LEP plan on its website at <https://www.ozarkstransportation.org/our-resources/civil-rights>.

Any person, including social service, non-profit, and law enforcement agencies and other community partners with internet access will be able to access the plan. For those without personal internet access, all Greene County Libraries offer free internet access. Copies of the LEP plan will be provided to the Missouri Department of Transportation, Federal Highway Administration, the Federal Transit Administration, and any person or agency requesting a copy. Each OTO member will be provided with a copy and will be educated on the importance of providing language assistance. An LEP person may obtain copies of the plan upon request.

Any questions or comments regarding this plan should be directed to the OTO Title VI Coordinator:

David Knaut
Ozarks Transportation Organization
2208 W Chesterfield Boulevard, Suite 101
Springfield, MO 65807
Phone: (417) 865-3047 X107
Fax: (417) 862-6013
Email – dknaut@ozarkstransportation.org

Boards and Committees

The OTO has two established boards and two established committees, which are the Board of Directors, Local Coordinating Board for Transit, Technical Planning Committee, and Bicycle and Pedestrian Advisory Committee. These boards and committees also select subcommittee's members on an as needed basis.

The established OTO boards and committees are filled by members who are authorized by the municipalities or agencies where they are elected or employed, as well as citizen-at-large members appointed by the board or committee. These appointments are filled by elected officials, managers, and staff as the member municipality or agency designates. OTO has no control over these appointments other than providing available positions and term limit guidance. OTO does not select board or committee members but rather provides opportunity for participation. Table 2 shows the current racial makeup of the OTO's boards and committees.

Board of Directors

The purpose of the Board of Directors will be to serve as the designated Metropolitan Planning Organization (MPO) for the approved Transportation Planning Area (TPA), in order to provide official decision-making responsibility for the Ozarks Transportation Organization. The coordination of elected officials and policy makers at this decision-making level allows for a broad geographical impact on transportation planning decisions.

Membership: Appointed elected officials of counties and municipalities, board members of City Utilities and Springfield-Branson National Airport, and Citizens at-large positions nominated by the City of Springfield (2), Christian County (1), and the Board of Directors (1).

Technical Planning Committee

The purpose of the Technical Planning Committee is to analyze issues arising during the conduct of the Springfield Transportation Study Area from a technical perspective and make recommendations to the Board of Directors. The purpose is also to provide a linkage between planning and implementation.

The Technical Planning Committee shall be composed of people involved in planning, engineering, public policy, or related fields and whose experience and expertise is valuable for supporting the Ozarks Transportation Organization.

Membership: Appointed staff by the municipal agency.

Local Coordinating Board for Transit

The purpose of the Local Coordinating Board for Transit is to confer with and advise on the effectiveness of coordinating transportation in the Ozarks Transportation Organization study area, and to be a problem-solving entity, where possible. The goals of the Local Coordinating Board for Transit will be the same as those established in the OTO Transit Coordination Plan. In addition, the Local Coordinating Board for Transit will analyze issues arising within the planning area of the Ozarks Transportation Organization from a human services transit perspective and make recommendations to the MPO Board of Directors.

Membership: People involved in planning, transit, human services, safety, or related fields and whose experience and expertise is valuable for supporting the OTO.

Bicycle and Pedestrian Advisory Committee

The purpose of the Bicycle and Pedestrian Advisory Committee is to improve bicycling and pedestrian conditions for commuters, children and recreational bicyclists and walkers of the area. The goals of the committee will be the same of those established in the Regional OTO Bicycle and Pedestrian Plan. In addition, the committee will analyze issues arising within the planning area of the Ozarks Transportation Organization from a bicycle and pedestrian perspective and make recommendations to the Technical Planning Committee.

Membership: People involved in planning, bicycle/pedestrian advocacy, safety, or related fields and whose experience and expertise is valuable for supporting the OTO.

Ethnic breakdown of the boards and committees for the OTO

Table 2: Board and Committee Members

Board or Committee	White	Black or African American	Native Hawaiian or Other Pacific Islander	Asian	American Indian or Alaskan Native	Some Other Race	Did not reply or preferred not to answer.
Board of Directors	64%	0	0	0	3%	0	33%
Local Coordinating Board for Transit	60%	0	0	3.5%	3.5%	0	29%
Technical Planning Committee	62%	0	0	0	0	0	38%
Bicycle and Pedestrian Committee	57%	0	0	0	0	0	43%

Board or Committee	Hispanic or Latino	Not Hispanic or Latino	Did not reply or preferred not to answer.
Board of Directors	0	56%	44%
Local Coordinating Board for Transit	0	71%	29%
Technical Planning Committee	0	57%	43%
Bicycle and Pedestrian Committee	0	64%	36%

Sub-Recipient Monitoring

The OTO is a sub-recipient of the State of Missouri and does not have any of its own sub-recipients to monitor. OTO reports to the Missouri Department of Transportation (MoDOT) all Title VI activities, helping MoDOT to meet their own requirements. If OTO becomes a direct recipient of FTA funding, OTO will adopt guidelines in the Program Management Plan that will ensure federal financial assistance will pass through in a nondiscriminatory manner and that all sub-recipients comply to required federal guidelines, including but not limited to, Title VI of the 1964 Civil Rights Act. OTO will monitor sub-recipient compliance on a regular basis, including but not limited to, annual Title VI reporting on compliance and during grant applications. OTO will provide assistance to sub-recipients to create awareness and compliance of federal requirements.

Title VI Equity Facility Analysis

The OTO has not constructed any facilities.

Title VI - Requirements for MPOs: FTA Circular 4702.1B (Chapter VI)

Metropolitan Planning Organizations (MPO) and other planning entities must submit:

- All requirements set out in Chapter III (General Requirements)
- The requirements set out in Chapter IV (Transit Provider) if the MPO is a provider of fixed route public transportation
- Demographic profile of the metropolitan area
- A description of the procedures by which the mobility needs of minority populations are identified and considered within the planning process
- Demographic maps that show the impacts of the distribution of State and Federal funds in the aggregate for public transportation projects
- Analysis of the MPO's transportation system investments that identifies and addresses any disparate impacts
- Description of the procedures the agency uses to ensure nondiscriminatory passthrough of FTA financial assistance (if requested)
- Description of the procedures the agency uses to provide assistance to potential Subrecipients in a nondiscriminatory manner (if requested)

Demographic profile of the metropolitan area

OTO considers the impact that its programs may have on the mobility needs of Title VI population. OTO identifies the Title VI population using census block data, as well as other means, including transit-related user and provider surveys.

The OTO area's estimated population, from the 2017-2022 ACS 5-year Estimates, is about 86.4% White, 3.3% African American, 0.6% Native American, and 2.3% Asian. Regardless of race, 16,269 people, or 4.6% of the population, were estimated to be of Hispanic or Latino origin. Table 3, on page 18, contains this information.

Table 3: OTO Race and Ethnicity by Jurisdiction

Geographic Area Name	Total population	One race							Two or more races	Hispanic or Latino (of any race)
		Total, One Race	White	Black or African American	American Indian and Alaska Native	Asian	Native Hawaiian and Other Pacific Islander	Some other race		
Christian County	13,253	12,702	12,189	166	50	113	29	155	551	400
Greene County	63,986	60,046	54,884	1,350	168	2,347	60	1,237	3,940	2,908
Battlefield	7,516	6,927	6,458	160	10	175	3	121	589	296
Fremont Hills	1,313	1,246	1,172	5	0	32	8	29	67	36
Nixa	27,151	26,157	24,404	374	219	655	19	486	994	1,109
Ozark	25,998	24,586	23,602	455	129	92	51	257	1,412	918
Republic	21,910	20,963	19,446	596	162	342	0	417	947	1,073
Springfield	185,307	174,165	156,615	8,669	1,265	4,343	446	2,827	11,142	9,154
Strafford	3,003	2,809	2,633	45	12	48	0	71	194	140
Willard	7,338	7,151	6,867	41	64	60	0	119	187	235
OTO Region	356,775	336,752	308,270	11,861	2,079	8,207	616	5,719	20,023	16,269

Source: US Census Bureau, 2018-2022 American Community Survey 5-Year Estimates, Table B02001 and B03003

Map of Minority Population

Figure 2, on page 20, shows the minority population by census block groups in the OTO service area. Significant concentrations of minority populations are located within the City of Springfield, north of the intersection of Interstate 44, Missouri State Highway 13, and southeast of the intersection of US 160 and US 65. Based on the estimates in Table 3, 13.6% of the population in the OTO region is comprised of racial minorities, which is an estimated 3.8 percent increase from the approved 2021 Title VI plan. The largest increase came in the category of two or more races which doubled since the last plan.

Map of Hispanic or Latino Population

Figure 3, on page 21, shows the Hispanic population by census block groups in the OTO service area. The Hispanic populations in the OTO service area are concentrated within the city of Springfield, between the City of Republic and the City of Battlefield and in central parts of the City of Nixa. It is estimated that 4.6% of the population in the OTO service area is comprised of those that are of Hispanic or Latino Origin, which is an estimated 0.9 increase compared to the data from the 2021 Title VI plan.

Map of Low Income Population

Figure 4, on page 22 shows the low-income populations by census block groups in the OTO service areas. According to the estimates, 12.9% of those who live in the OTO's service area are living below poverty level, which is an estimated decrease of 2% from the 2021 Title VI plan. The census block groups with the highest percentage of low-income population are located in central and northern Springfield.

Map of Disabled Population

Figure 5, on page 23, identifies the population of those that are disabled by census tracts in the OTO service area. Currently, an estimated 14.4% of the population within the OTO service area are classified as having a disability compared to an estimated 14.7% in the 2021 Title VI Plan. The Northwest section of Springfield shows the highest proportions of individuals with disabilities in the OTO service, area, though disabilities are common throughout the region.

Figure 2 Percent Minority

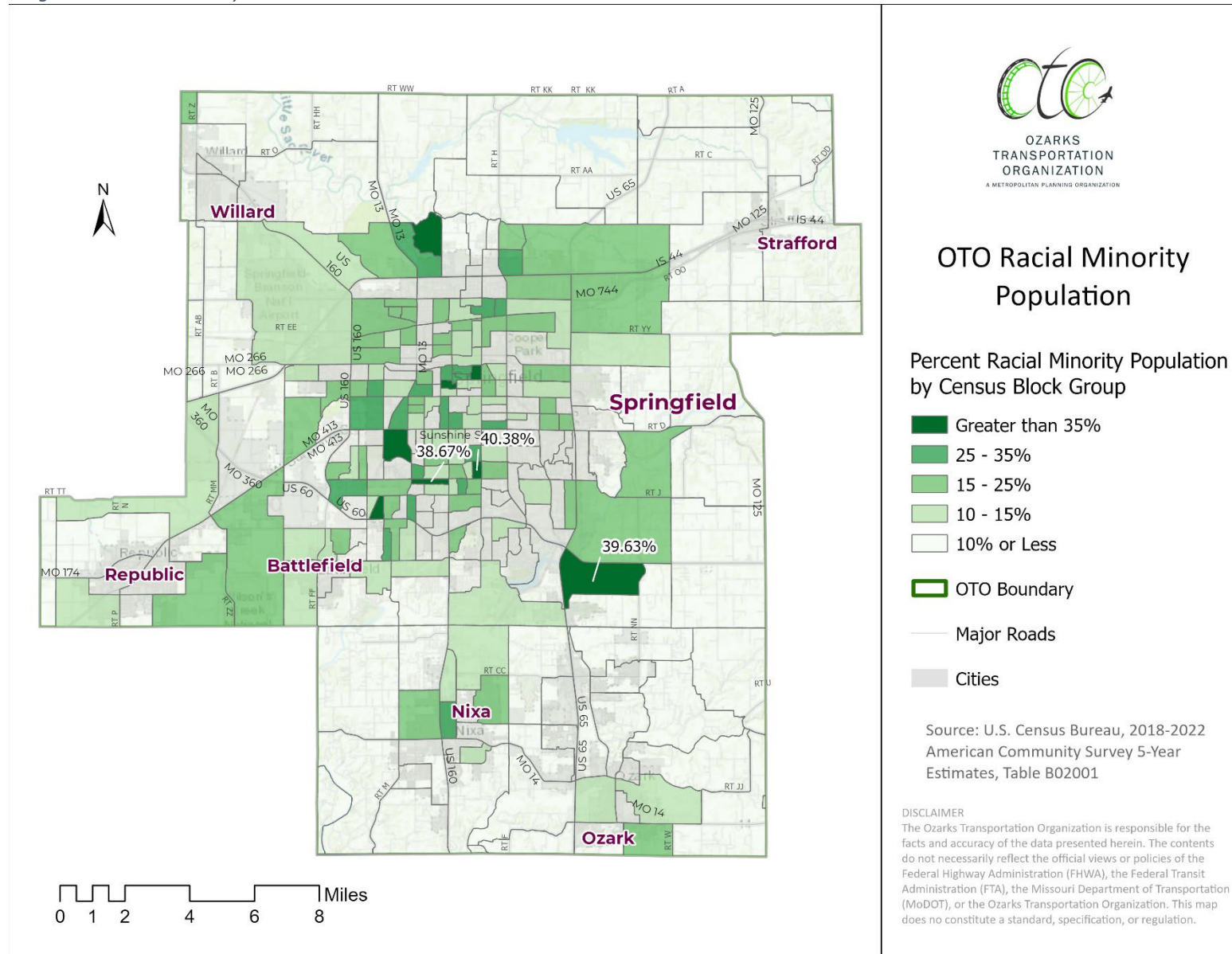

Figure 2 Percent Hispanic

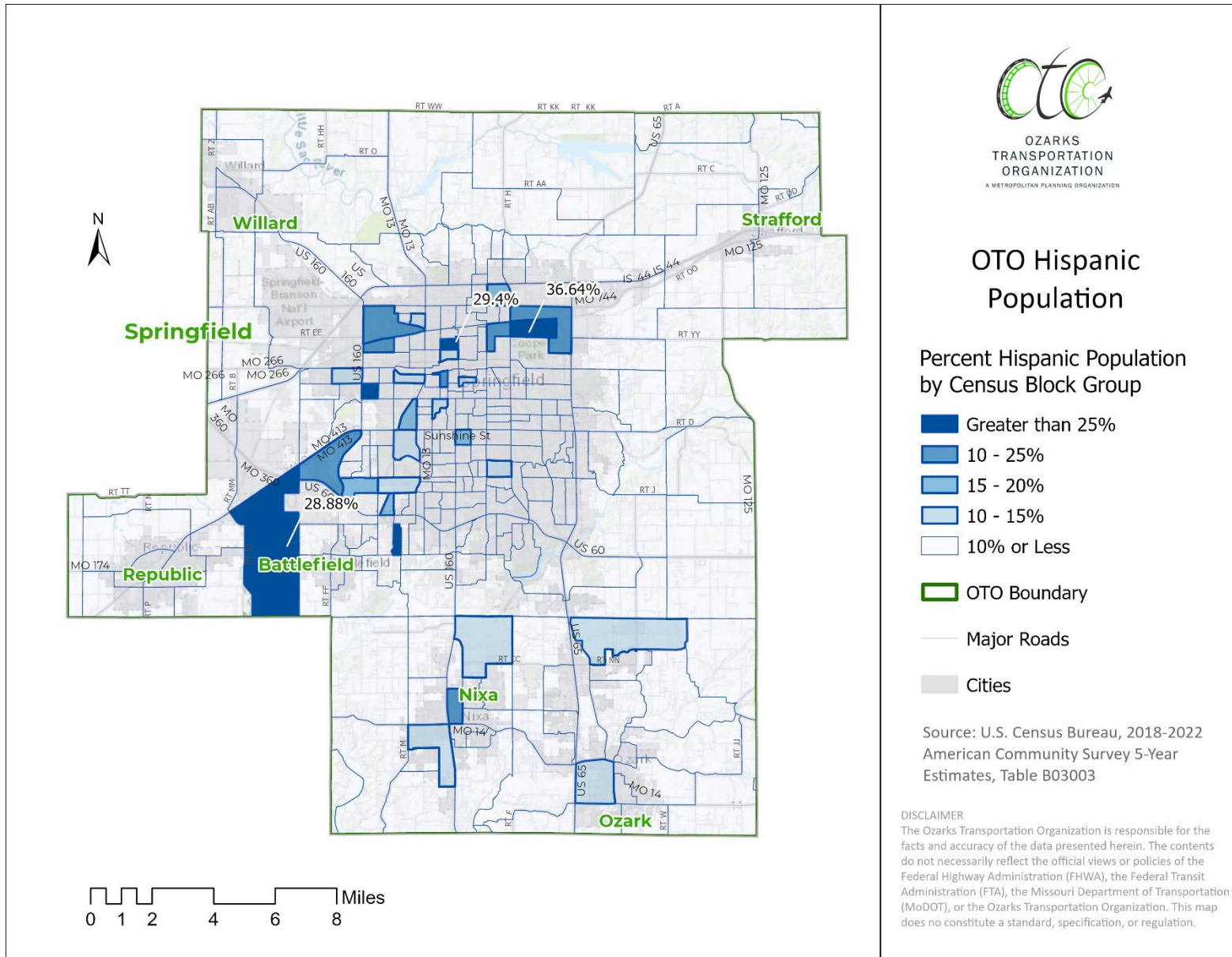

Figure 3 Percent Living Below Poverty

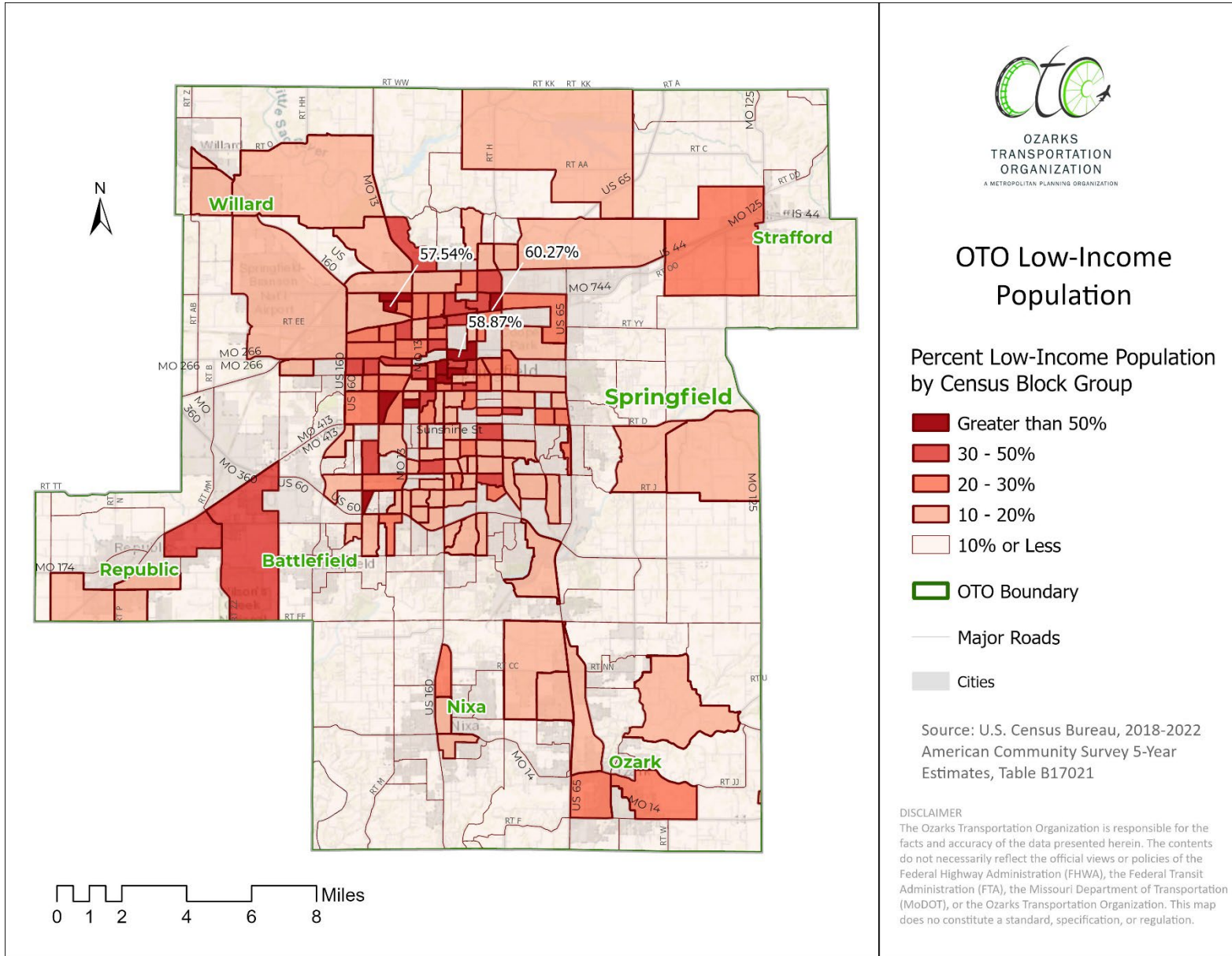
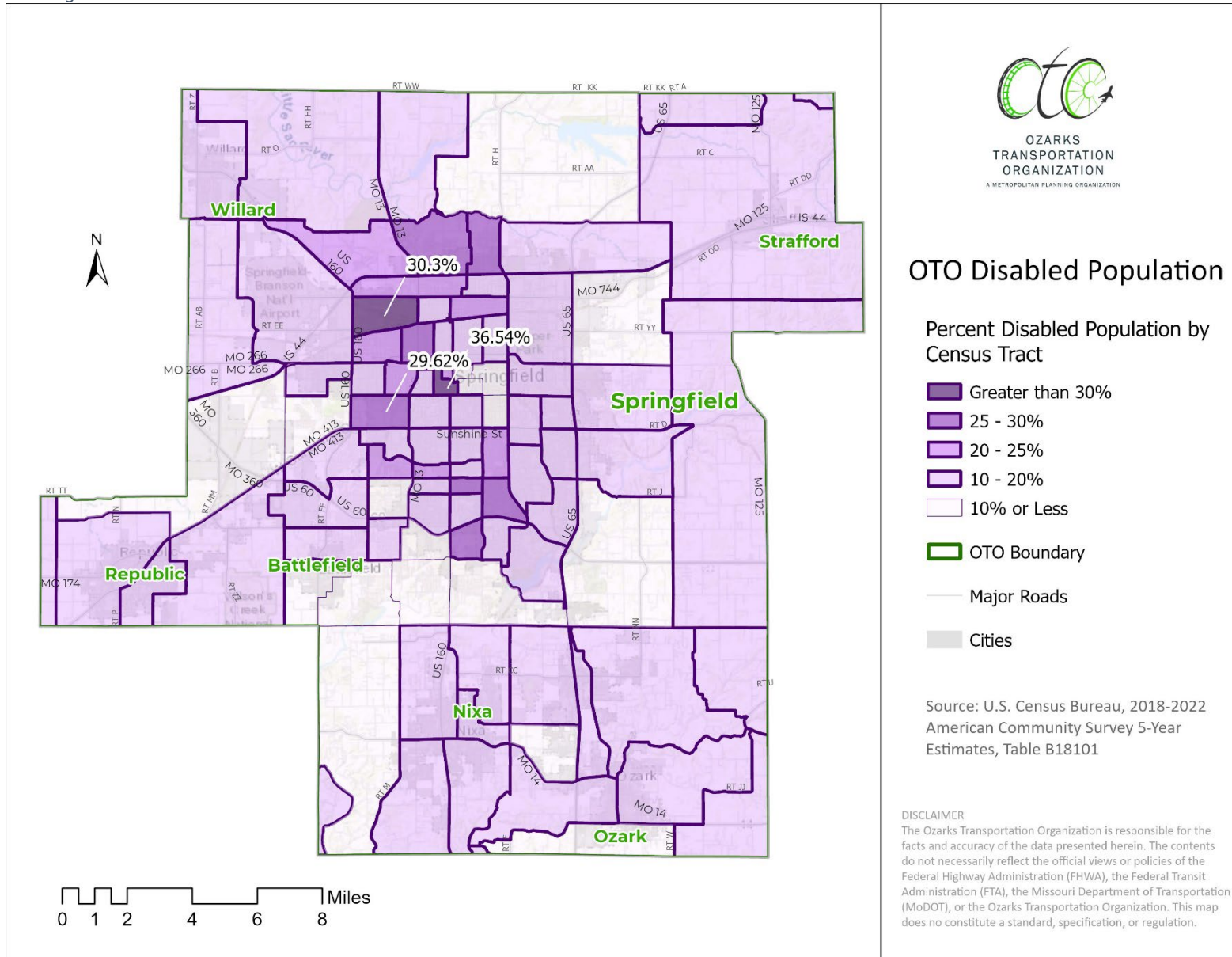

Figure 4 Percent Disabled



Fixed Route Transit Requirements

The OTO is not a Transit Provider and therefore is not subject to Chapter IV Title VI requirements.

Mobility Needs of Minority Populations

The mobility needs of minority populations are identified through engagement efforts, data collection and analysis of available census data, public comment, and other available sources. The policy and guidance for public engagement is established in the OTO Public Participation Plan. The OTO's policy for public engagement includes, but is not limited to, activities and outreach efforts such as surveys, public meetings, open house, public notices, website and Facebook postings, the OTO public bulletin board, emails and public comments, or other means of communication that help promote the inclusion of the planning process to all.

Data analysis through GIS mapping techniques is vital for helping to identifying and engaging underrepresented populations. Various data sets are used in map making and are included in the OTO products that consider populations needs of minorities, Limited English Proficiency people, and low-income populations. The OTO also utilizes data for planning products and can identify other population by age, persons per square mile, persons under the age of 18, persons over the age of 65, Hispanic populations, disabled populations, zero car households, employment populations, and other populations as needed.

The engagement and data analysis techniques employed by the OTO have significant impacts on the organization's key planning products, including the Long-Range Transportation Plan, the Transportation Improvement Program, the Congestion Management Process, and Transit Coordination Plan. The planning products include detailed analyses, public input, and broad, inclusive goals. Based upon the goals of these key documents, the Unified Planning Work Program guides staff work assignments. The inclusion of Title VI related goals ensures OTO staff regularly consider and include mobility needs of minority populations in their daily activities.

Distribution of State and Federal Funds for Public Transportation Projects

City Utilities of Springfield operates the only fixed route bus service in the OTO service area. Figure 6 on page 25 shows a map of the City Utilities fixed routes compared to the minority populations by census tracts in the MPO boundaries. It is estimated that 13.6 percent of the population within the OTO boundaries are minorities.

Figure 5 Minority Population with CU Bus Route

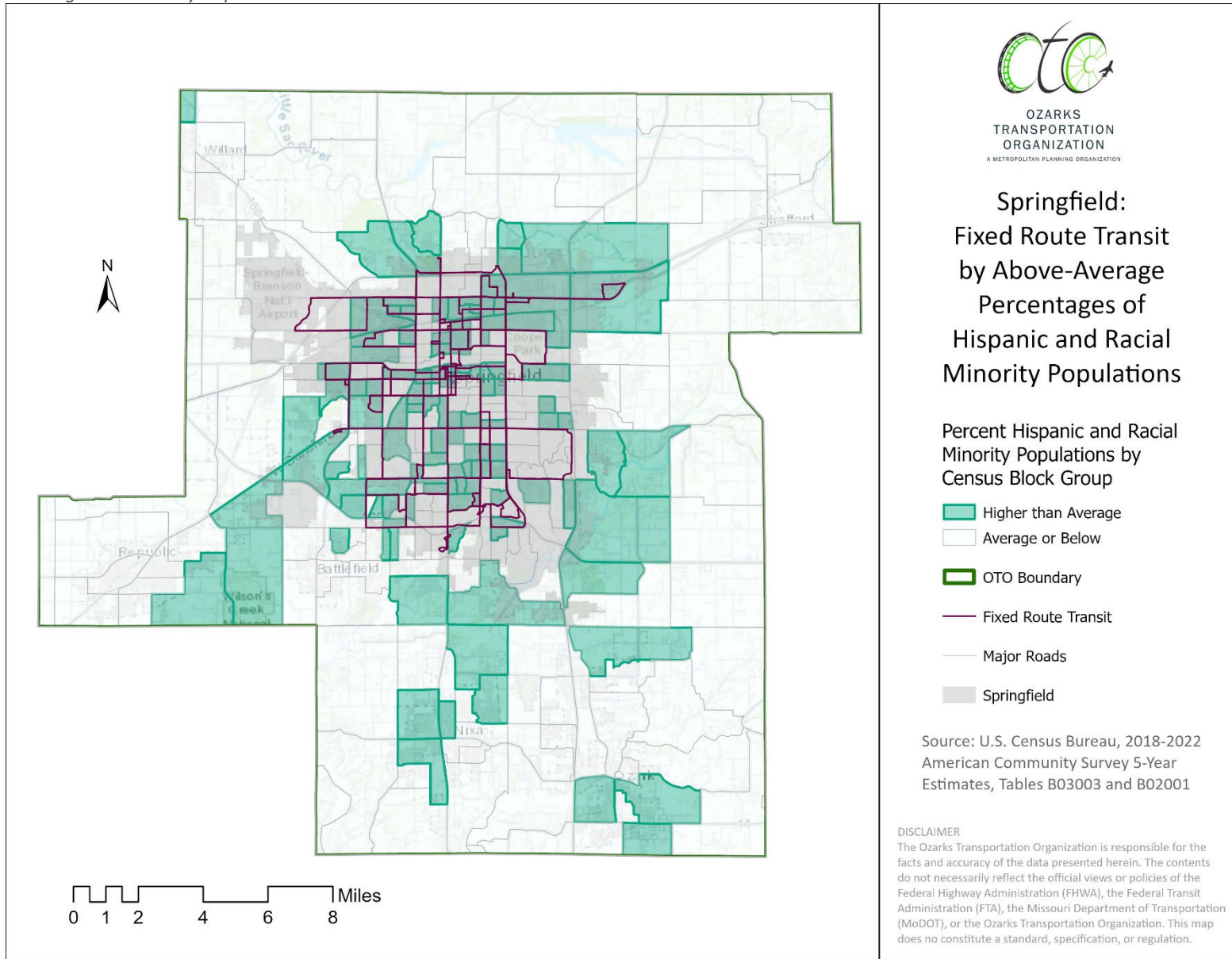

Analysis of Disparate Impacts

The OTO plays a vital role in the allocation of funds for transportation projects within the Springfield Urbanized area. To remain in compliance under 49 U.S.C. 5303(j), the OTO is required to maintain a Transportation Improvement Program (TIP). The TIP shows the breakdown of the funds which are allocated for regional transportation projects. Section F of the 2024-2027 Transportation Improvement Program shows the allocation of funds related to transit projects. Each grant has its own guidelines that must be followed in the process for awarding grants. The current and prior Transportation Improvement Programs are available on OTO’s webpage: <https://www.ozarkstransportation.org/what-we-do/transportation-improvement-program>.

The OTO administers a grant selection process for Infrastructure Investment and Jobs Act (IIJA) programs. These programs include 5307 Urbanized Area Formula Grants, 5310 Enhanced Mobility for Seniors and Individuals with Disabilities Grants, and 5339 The Bus and Bus facilities Grants. City Utilities – Transit is the only eligible recipient for the 5307 and 5339 program that has indicated interest in applying for these funds. Funds from these programs will be automatically awarded to City Utilities – Transit until such time as another organization submits a letter of interest to the OTO. The OTO’s Local Coordinating Board for Transit (LCBT) is the body that scores and ranks each FTA Section 5310 application received during an open application process. The application process has a standardized score sheet for each program that is used during the selection process. The selection criteria can be found in the OTO TIP. The LCBT then recommends awards of grant funding to highest scored application and continues making recommendation of awards in descending order until all funds are expended. The recommendations are then taken to the OTO board of directions, where the final award is approved. The Designated Recipients will administer the funds depending on the program. Table 4 shows the aggregate funding breakdown for transit grants for the FY 2024-2027 TIP, with amendments.

Table 4: Yearly Summary of funding for Transit Projects

Summary of Funding for Transit Projects, 2024-2027				
	Federal Funds	Local Funds	State Funds	Total
FTA 5307	\$18,769,804	\$37,352,306	\$217,500	\$56,339,610
FTA 5310	\$2,264,774	\$532,224	\$0	\$2,796,998
FTA 5339	\$1,702,930	\$378,000	\$0	\$2,080,930
Total	\$22,737,508	\$38,262,530	\$217,500	\$61,217,538
Source: FY 2024-2027 TIP, might change based on amendments				

Fixed route public transportation investments are focused in areas with above average concentrations of minority populations, as previously shown in Figure 6. No disparate impacts have been created.

Nondiscriminatory Passthrough of FTA financial assistance (if requested)

Currently, the OTO has no passthrough of FTA funds. If OTO becomes a direct recipient of FTA funding, OTO will adopt guidelines in the Program Management Plan that will ensure federal financial assistance will pass through in a nondiscriminatory manner and that all sub-recipients comply to required federal guidelines, including but not limited to, Title VI of the 1964 Civil Rights Act.

Nondiscrimination in subrecipient assistance (if requested)

Currently, the OTO has no passthrough of FTA funds. If OTO becomes a direct recipient of FTA funding, OTO will adopt guidelines in the Program Management Plan that will ensure that all sub-recipients comply to required federal guidelines, including but not limited to, Title VI of the 1964 Civil Rights Act. OTO will monitor sub-recipient compliance on a regular basis, including but not limited to, annual Title VI reporting on compliance and during grant applications. OTO will provide assistance to sub-recipients to create awareness and compliance of federal requirements.

ADA - Program Access

The OTO has consistently worked to make its public meetings accessible to those with disabilities. Meetings are held at accessible locations and interpreters are always available with adequate notice. Efforts have also been undertaken to ensure the OTO's electronic documents and website are as accessible as possible.

Public Meetings

The OTO holds most of its public meetings in its conference room. The OTO offices are generally accessible, though, as described below, OTO has shared information regarding deficiencies with the building's owner. When meetings are held off-site, public buildings are used whenever possible to ensure accessibility.

On-Site

A building assessment was completed in May 2017 to evaluate the accessibility of the exterior and interior path. In response to this assessment, adjustments were made to the OTO entrance door and to the accessible condition of the OTO conference room. The conference room will be maintained in as an accessible condition as possible. The OTO leases its current space and therefore cannot control building elements outside of its leased space, but identified deficiencies were shared with the building's owner, see Appendix G. The building owner corrected issues related to the speed at which the main entrance doors closed. Since the May 2017 assessment, the OTO's ADA Coordinator has not noticed any alterations to the building that have warranted a reevaluation of the building's accessibility.

Off-Site

It is the policy of the OTO to hold off-site public meetings at accessible public buildings. Public libraries will be the primary location of off-site locations. These buildings offer accessible paths of travel and accessible restrooms. If public libraries are not available, city halls/county courthouses will be considered next. These buildings can have accessibility issues, but are more likely to be in compliance than many privately-owned community meeting spaces. If meetings need to be held in a community with no accessible meeting rooms, meeting packets should be assembled so they can be taken out to citizens unable to access the meeting room.

Electronic Documents

The OTO produces many electronic documents, such as PDFs. These documents have certain accessibility challenges associated with them. However, there are many techniques that can be utilized to make electronic documents more accessible. It is the policy of the OTO to ensure as many accessibility best practices are implemented in key documents as possible. Appendix H contains a best practice guide for creating accessible documents in MS Word that will be utilized by OTO staff.

Website

The OTO launched a redesigned website in 2019. The OTO requested its contractor to comply with WCAG 2.0 Level A requirements as much as possible. Subsequently, OTO staff works to ensure those included accessibility features have been kept current and have been added to new content.

Implementation

An implementation guide, along with a resource reference sheet, has been created to direct staff efforts in complying with this Title VI/ADA program. The implementation guide covers public notices, public meetings, and internal staff training. The guide can be reviewed in Appendix I. The resource reference sheet will be used to help train new hires and help all staff members stay current on resources available to them. The reference sheet can be reviewed in Appendix J. These documents will be updated as needed over the three-year term of this plan.

Appendix A: Standard DOT Assurances

The United States Department of Transportation (USDOT) Standard Title VI/Non-Discrimination Assurances
DOT Order No. 1050.2A

The Ozarks Transportation Organization (herein referred to as the "Recipient"), **HEREBY AGREES THAT**, as a condition to receiving any Federal financial assistance from the U.S. Department of Transportation (DOT), through the FHWA and FTA, is subject to and will comply with the following:

Statutory/Regulatory Authorities

- Title VI of the Civil Rights Act of 1964 (42 U.S.C. § 2000d et seq., 78 stat. 252), (prohibits discrimination on the basis of race, color, national origin);
- 49 C.F.R. Part 21 (entitled Non-discrimination In Federally-Assisted Programs Of The Department Of Transportation-Effectuation Of Title VI Of The Civil Rights Act Of 1964);
- 28 C.F.R. section 50.3 (U.S. Department of Justice Guidelines for Enforcement of Title VI of the Civil Rights Act of 1964);

The preceding statutory and regulatory cites hereinafter are referred to as the "Acts" and "Regulations," respectively.

General Assurances

In accordance with the Acts, the Regulations, and other pertinent directives, circulars, policy, memoranda, and/or guidance, the Recipient hereby gives assurance that it will promptly take any measures necessary to ensure that:

"No person in the United States shall, on the grounds of race, color, or national origin, be excluded from participation in, be denied the benefits of, or be otherwise subjected to discrimination under any program or activity, "for which the Recipient receives Federal financial assistance from DOT, including the FHWA and FTA.

The Civil Rights Restoration Act of 1987 clarified the original intent of Congress, with respect to Title VI and other Non-discrimination requirements (The Age Discrimination Act of 1975, and Section 504 of the Rehabilitation Act of 1973), by restoring the broad, institutional-wide scope and coverage of these non-discrimination statutes and requirements to include all programs and activities of the Recipient, so long as any portion of the program is Federally assisted.

Specific Assurances

More specifically, and without limiting the above general Assurance, the Recipient agrees with and gives the following Assurances with respect to its Federally assisted Ozarks Transportation Organization:

1. The Recipient agrees that each "activity," "facility," or "program," as defined in §§ 21.23(b) and 21.23(e) of 49 C.F.R. § 21 will be (with regard to an "activity") facilitated, or will be (with regard to a "facility") operated, or will be (with regard to a "program") conducted in compliance with all requirements imposed by, or pursuant to the Acts and the Regulations.

2. The Recipient will insert the following notification in all solicitations for bids, Requests For Proposals for work, or material subject to the Acts and the Regulations made in connection with all Ozarks Transportation Organization and, in adapted form, in all proposals for negotiated agreements regardless of funding source:

"The Ozarks Transportation Organization, in accordance with the provisions of Title VI of the Civil Rights Act of 1964 (78 Stat. 252, 42 U.S.C. §§ 2000d to 2000d-4) and the Regulations, hereby notifies all bidders that it will affirmatively ensure that any contract entered into pursuant to this advertisement, disadvantaged business enterprises will be afforded full and fair opportunity to submit bids in response to this invitation and will not be discriminated against on the grounds of race, color, or national origin in consideration for an award."

3. The Recipient will insert the clauses of Appendix A and E of this Assurance in every contract or agreement subject to the Acts and the Regulations.
4. The Recipient will insert the clauses of Appendix B of this Assurance, as a covenant running with the land, in any deed from the United States effecting or recording a transfer of real property, structures, use, or improvements thereon or interest therein to a Recipient.
5. That where the Recipient receives Federal financial assistance to construct a facility, or part of a facility, the Assurance will extend to the entire facility and facilities operated in connection therewith.
6. That where the Recipient receives Federal financial assistance in the form, or for the acquisition of real property or an interest in real property, the Assurance will extend to rights to space on, over, or under such property.
7. That the Recipient will include the clauses set forth in Appendix C and Appendix D of this Assurance, as a covenant running with the land, in any future deeds, leases, licenses, permits, or similar instruments entered into by the Recipient with other parties:
 - a. for the subsequent transfer of real property acquired or improved under the applicable activity, project, or program; and
 - b. for the construction or use of, or access to, space on, over, or under real property acquired or improved under the applicable activity, project, or program.
8. That this Assurance obligates the Recipient for the period during which Federal financial assistance is extended to the program, except where the Federal financial assistance is to provide, or is in the form of, personal property, or real property, or interest therein, or structures or improvements thereon, in which case the Assurance obligates the Recipient, or any transferee for the longer of the following periods:
 - a. the period during which the property is used for a purpose for which the Federal financial assistance is extended, or for another purpose involving the provision of similar services or benefits; or
 - b. the period during which the Recipient retains ownership or possession of the property.
9. The Recipient will provide for such methods of administration for the program as are found by the Secretary of Transportation or the official to whom he/she delegates specific authority to give reasonable guarantee that it, other recipients, sub-

recipients, sub-grantees, contractors, subcontractors, consultants, transferees, successors in interest, and other participants of Federal financial assistance under such program will comply with all requirements imposed or pursuant to the Acts, the Regulations, and this Assurance.

10. The Recipient agrees that the United States has a right to seek judicial enforcement with regard to any matter arising under the Acts, the Regulations, and this Assurance.

By signing this ASSURANCE, Ozarks Transportation Organization also agrees to comply (and require any sub-recipients, sub-grantees, contractors, successors, transferees, and/or assignees to comply) with all applicable provisions governing the Ozarks Transportation Organization access to records, accounts, documents, information, facilities, and staff. You also recognize that you must comply with any program or compliance reviews, and/or complaint investigations conducted by the Ozarks Transportation Organization. You must keep records, reports, and submit the material for review upon request to Ozarks Transportation Organization, or its designee in a timely, complete, and accurate way. Additionally, you must comply with all other reporting, data collection, and evaluation requirements, as prescribed by law or detailed in program guidance.

Ozarks Transportation Organization gives this ASSURANCE in consideration of and for obtaining any Federal grants, loans, contracts, agreements, property, and/or discounts, or other Federal-aid and Federal financial assistance extended after the date hereof to the recipients by the U.S. Department of Transportation under the Ozarks Transportation Organization. This ASSURANCE is binding on the State of Kansas, other recipients, sub-recipients, sub-grantees, contractors, subcontractors and their subcontractors', transferees, successors in interest, and any other participants in the Ozarks Transportation Organization. The person(s) signing below is authorized to sign this ASSURANCE on behalf of the Recipient.



Sara Fields, Executive Director

5/20/2024
Date

APPENDIX A

During the performance of this contract, the contractor, for itself, its assignees, and successors in interest (hereinafter referred to as the "contractor") agrees as follows:

1. **Compliance with Regulations:** The contractor (hereinafter includes consultants) will comply with the Acts and the Regulations relative to Non-discrimination in Federally-assisted programs of the U.S. Department of Transportation, the FHWA and FTA, as they may be amended from time to time, which are herein incorporated by reference and made a part of this contract.
2. **Non-discrimination:** The contractor, with regard to the work performed by it during the contract, will not discriminate on the grounds of race, color, or national origin in the selection and retention of subcontractors, including procurements of materials and leases of equipment. The contractor will not participate directly or indirectly in the discrimination prohibited by the Acts and the Regulations, including employment practices when the contract covers any activity, project, or program set forth in Appendix B of 49 CFR Part 21.
3. **Solicitations for Subcontracts, Including Procurements of Materials and Equipment:** In all solicitations, either by competitive bidding, or negotiation made by the contractor for work to be performed under a subcontract, including procurements of materials, or leases of equipment, each potential subcontractor or supplier will be notified by the contractor of the contractor's obligations under this contract and the Acts and the Regulations relative to Non-discrimination on the grounds of race, color, or national origin.
4. **Information and Reports:** The contractor will provide all information and reports required by the Acts, the Regulations, and directives issued pursuant thereto and will permit access to its books, records, accounts, other sources of information, and its facilities as may be determined by the Recipient or U.S. Department of Transportation, FHWA and FTA, as they may be amended to be pertinent to ascertain compliance with such Acts, Regulations, and instructions. Where any information required of a contractor is in the exclusive possession of another who fails or refuses to furnish the information, the contractor will so certify to the Recipient or the U.S. Department of Transportation, FHWA, and FTA, as appropriate, and will set forth what efforts it has made to obtain the information.
5. **Sanctions for Noncompliance:** In the event of a contractor's noncompliance with the Non- discrimination provisions of this contract, the Recipient will impose such contract sanctions as it or the U.S. Department of Transportation, FHWA, and FTA may determine to be appropriate, including, but not limited to:
 - a. withholding payments to the contractor under the contract until the contractor complies; and/or
 - b. cancelling, terminating, or suspending a contract, in whole or in part.
6. **Incorporation of Provisions:** The contractor will include the provisions of paragraphs one through six in every subcontract, including procurements of materials and leases of equipment, unless exempt by the Acts, the Regulations and directives issued pursuant thereto. The contractor will take action with respect to any subcontract or procurement as the Recipient or the U.S. Department of Transportation, FHWA, and FTA may direct as a means of enforcing such provisions including sanctions for noncompliance. Provided, that if the contractor becomes

APPENDIX B

CLAUSES FOR DEEDS TRANSFERRING UNITED STATES PROPERTY

The following clauses will be included in deeds effecting or recording the transfer of real property, structures, or improvements thereon, or granting interest therein from the United States pursuant to the provisions of Assurance 4:

NOW, THEREFORE, the U.S. Department of Transportation as authorized by law and upon the condition that the Ozarks Transportation Organization will accept title to the lands and maintain the project constructed thereon in accordance with the Infrastructure Investment and Jobs Act, the Regulations for the Administration of Ozarks Transportation Organization and the policies and procedures prescribed by the U.S. Department of Transportation, FHWA, and FTA of the U.S. Department of Transportation in accordance and in compliance with all requirements imposed by Title 49, Code of Federal Regulations, U.S. Department of Transportation, Subtitle A, Office of the Secretary, Part 21, Non-discrimination in Federally-assisted programs of the U.S Department of Transportation pertaining to and effectuating the provisions of Title VI of the Civil Rights Act of 1964 (78 Stat. 252; 42 U.S.C. § 2000d to 2000d-4), does hereby remise, release, quitclaim and convey unto the Ozarks Transportation Organization all the right, title and interest of the U.S. Department of Transportation in and to said lands described in Exhibit A attached hereto and made a part hereof.

(HABENDUM CLAUSE)

TO HAVE AND TO HOLD said lands and interests therein unto Ozarks Transportation Organization and its successors forever, subject, however, to the covenants, conditions, restrictions and reservations herein contained as follows, which will remain in effect for the period during which the real property or structures are used for a purpose for which Federal financial assistance is extended or for another purpose involving the provision of similar services or benefits and will be binding on the Ozarks Transportation Organization, its successors and assigns.

The Ozarks Transportation Organization, in consideration of the conveyance of said lands and interests in lands, does hereby covenant and agree as a covenant running with the land for itself, its successors and assigns, that (1) no person will on the grounds of race, color, or national origin, be excluded from participation in, be denied the benefits of, or be otherwise subjected to discrimination with regard to any facility located wholly or in part on, over, or under such lands hereby conveyed [,] [and]* (2) that the Ozarks Transportation Organization will use the lands and interests in lands and interests in lands so conveyed, in compliance with all requirements imposed by or pursuant to Title 49, Code of Federal Regulations, U.S. Department of Transportation, Subtitle A, Office of the Secretary, Part 21, Non-discrimination in Federally- assisted programs of the U.S. Department of Transportation, Effectuation of Title VI of the Civil Rights Act of 1964, and as said Regulations and Acts may be amended [, and (3) that in the event of breach of any of the above-mentioned non-discrimination conditions, the Department will have a right to enter or re-enter said lands and facilities on said land, and that above described land and facilities will thereon revert to and vest in and become the absolute property of the U.S. Department of Transportation and its assigns as such interest existed prior to this instruction].*

(*Reverter clause and related language to be used only when it is determined that such a clause is necessary in order to make clear the purpose of Title VI.)

APPENDIX C

CLAUSES FOR TRANSFER OF REAL PROPERTY ACQUIRED OR IMPROVED UNDER THE ACTIVITY, FACILITY, OR PROGRAM

The following clauses will be included in deeds, licenses, leases, permits, or similar instruments entered into by the Ozarks Transportation Organization pursuant to the provisions of Assurance 7(a):

- A. The (grantee, lessee, permittee, etc. as appropriate) for himself/herself, his/her heirs, personal representatives, successors in interest, and assigns, as a part of the consideration hereof, does hereby covenant and agree [in the case of deeds and leases add "as a covenant running with the land"] that:
 - 1. In the event facilities are constructed, maintained, or otherwise operated on the property described in this (deed, license, lease, permit, etc.) for a purpose for which a U.S. Department of Transportation activity, facility, or program is extended or for another purpose involving the provision of similar services or benefits, the (grantee, licensee, lessee, permittee, etc.) will maintain and operate such facilities and services in compliance with all requirements imposed by the Acts and Regulations (as may be amended) such that no person on the grounds of race, color, or national origin, will be excluded from participation in, denied the benefits of, or be otherwise subjected to discrimination in the use of said facilities.

- B. With respect to licenses, leases, permits, etc., in the event of breach of any of the above Non-discrimination covenants, Ozarks Transportation Organization will have the right to terminate the (lease, license, permit, etc.) and to enter, re-enter, and repossess said lands and facilities thereon, and hold the same as if the (lease, license, permit, etc.) had never been made or issued.*

- C. With respect to a deed, in the event of breach of any of the above Non-discrimination covenants, the Ozarks Transportation Organization will have the right to enter or re-enter the lands and facilities thereon, and the above described lands and facilities will there upon revert to and vest in and become the absolute property of the Ozarks Transportation Organization and its assigns.*

(*Reverter clause and related language to be used only when it is determined that such a clause is necessary to make clear the purpose of Title VI.)

APPENDIX D

CLAUSES FOR CONSTRUCTION/USE/ACCESS TO REAL PROPERTY ACQUIRED UNDER THE ACTIVITY, FACILITY OR PROGRAM

The following clauses will be included in deeds, licenses, permits, or similar instruments/agreements entered into by Ozarks Transportation Organization pursuant to the provisions of Assurance 7(b):

- A. The (grantee, licensee, permittee, etc., as appropriate) for himself/herself, his/her heirs, personal representatives, successors in interest, and assigns, as a part of the consideration hereof, does hereby covenant and agree (in the case of deeds and leases add, "as a covenant running with the land") that (1) no person on the ground of race, color, or national origin, will be excluded from participation in, denied the benefits of, or be otherwise subjected to discrimination in the use of said facilities, (2) that in the construction of any improvements on, over, or under such land, and the furnishing of services thereon, no person on the ground of race, color, or national origin, will be excluded from participation in, denied the benefits of, or otherwise be subjected to discrimination, (3) that the (grantee, licensee, lessee, permittee, etc.) will use the premises in compliance with all other requirements imposed by or pursuant to the Acts and Regulations, as amended, set forth in this Assurance.
- B. With respect to (licenses, leases, permits, etc.), in the event of breach of any of the above Non- discrimination covenants, Ozarks Transportation Organization will have the right to terminate the (license, permit, etc., as appropriate) and to enter or re-enter and repossess said land and the facilities thereon, and hold the same as if said (license, permit, etc., as appropriate) had never been made or issued.*
- C. With respect to deeds, in the event of breach of any of the above Non-discrimination covenants, Ozarks Transportation Organization will there upon revert to and vest in and become the absolute property of Ozarks Transportation Organization and its assigns.*

(*Reverter clause and related language to be used only when it is determined that such a clause is necessary to make clear the purpose of Title VI.)

involved in, or is threatened with litigation by a subcontractor, or supplier because of such direction, the contractor may request the Recipient to enter into any litigation to protect the interests of the Recipient. In addition, the contractor may request the United States to enter into the litigation to protect the interests of the United States.

APPENDIX E

During the performance of this contract, the contractor, for itself, its assignees, and successors in interest (hereinafter referred to as the "contractor") agrees to comply with the following non-discrimination statutes and authorities; including but not limited to:

Pertinent Non-Discrimination Authorities:

- Title VI of the Civil Rights Act of 1964 (42 U.S.C. § 2000d et seq., 78 stat. 252), (prohibits discrimination on the basis of race, color, national origin); and 49 CFR Part 21.
- The Uniform Relocation Assistance and Real Property Acquisition Policies Act of 1970, (42 U.S.C. § 4601), (prohibits unfair treatment of persons displaced or whose property has been acquired because of Federal or Federal-aid programs and projects);
- Federal-Aid Highway Act of 1973, (23 U.S.C. § 324 et seq.), (prohibits discrimination on the basis of sex);
- Section 504 of the Rehabilitation Act of 1973, (29 U.S.C. § 794 et seq.), as amended, (prohibits discrimination on the basis of disability); and 49 CFR Part 27;
- The Age Discrimination Act of 1975, as amended, (42 U.S.C. § 6101 et seq.), (prohibits discrimination on the basis of age);
- Airport and Airway Improvement Act of 1982, (49 USC § 471, Section 47123), as amended, (prohibits discrimination based on race, creed, color, national origin, or sex);
- The Civil Rights Restoration Act of 1987, (PL 100-209), (Broadened the scope, coverage and applicability of Title VI of the Civil Rights Act of 1964, The Age Discrimination Act of 1975 and Section 504 of the Rehabilitation Act of 1973, by expanding the definition of the terms "programs or activities" to include all of the programs or activities of the Federal-aid recipients, sub-recipients and contractors, whether such programs or activities are Federally funded or not);
- Titles II and III of the Americans with Disabilities Act, which prohibit discrimination on the basis of disability in the operation of public entities, public and private transportation systems, places of public accommodation, and certain testing entities (42 U.S.C. §§ 12131-12189) as implemented by Department of Transportation regulations at 49 C.F.R. parts 37 and 38;
- The Federal Aviation Administration's Non-discrimination statute (49 U.S.C. § 47123) (prohibits discrimination on the basis of race, color, national origin, and sex);
- Executive Order 12898, Federal Actions to Address Environmental Justice in Minority Populations and Low-Income Populations, which ensures Non-discrimination against minority populations by discouraging programs, policies, and activities with disproportionately high and adverse human health or environmental effects on minority and low-income populations;
- Executive Order 13166, Improving Access to Services for Persons with Limited English Proficiency, and resulting agency guidance, national origin discrimination includes discrimination because of Limited English proficiency (LEP). To ensure compliance with Title VI, you must take reasonable steps to ensure that LEP persons have meaningful access to your programs (70 Fed. Reg. at 74087 to 74100);
- Title IX of the Education Amendments of 1972, as amended, which prohibits you from discriminating because of sex in education programs or activities (20 U.S.C. 1681 et seq).

**Appendix B: Title VI/ADA Complaint Procedures and Form,
including Title VI Public Notice**



OZARKS TRANSPORTATION ORGANIZATION
A METROPOLITAN PLANNING ORGANIZATION

TITLE VI/ADA POLICY AND COMPLAINT PROCEDURE

Title VI, 42 U.S.C. § 2000d et seq., was enacted as part of the landmark Civil Rights Act of 1964. It prohibits discrimination on the basis of race, color, and national origin in programs and activities receiving federal financial assistance.

Two Executive Orders and related statutes define populations that are protected under Title VI. Executive Order 12898 is concerned with environmental justice for minority and low-income populations. Executive Order 13166 is concerned with providing equal access to services and benefits for individuals with limited English proficiency.

The Ozarks Transportation Organization (OTO) has in place a Title VI/ADA Complaint Procedure, which outlines a process for local disposition of Title VI/ADA complaints and is consistent with guidelines found in Chapter VII of the Federal Transit Administration Circular 4702.1B, dated October 1, 2012. If you believe that the Metropolitan Planning Organization (MPO) has discriminated your civil rights on the basis of race, color, national origin, age, disability, religion, sex or English proficiency you may file a written complaint by following the procedure outlined below under Title VI/ADA Complaint Procedure:

OTO RESPONSIBILITIES FOR TITLE VI/ADA

According to Federal Law the Ozarks Transportation Organization shall be responsible for the following:

- Analyze regional data to identify minority and low-income population concentrations as well with individuals with limited English proficiency within the region. Commitment of staff and financial resources for this technical work can be demonstrated in the Work Program. The MPO staff can explain how the technical resources (models, Geographic Information Systems (GIS), data bases and analysis, etc.) are used for Title VI-related planning and analysis. The MPO might be asked to discuss this and how the technical information generated is used in planning.
- Where necessary, provide member agencies with regional data that assists them to identify minority and low-income populations in their subregion or service area. The team might discuss the extent to which this information is useful and used by participating agencies.
- Establish appropriate standards, measures, and benchmarks, and analyze the transportation process, Transportation Improvement Program (TIP), and other MPO actions, plans, and investments to ensure they are consistent with, and do not violate, Title VI of the Civil Rights Act and the Executive Order on Environmental Justice. Effort in these areas might be demonstrated in the Unified Planning Work Program (UPWP), as well as within the TIP, and in discussions of how this analysis is used in the planning process.
- Ensure that members of low income and minority communities, including Indian tribal governments, are provided with full opportunities to engage in the regional transportation planning process. This includes acting to eliminate language, mobility, temporal, and other obstacles to allow them to fully participate in the process. The MPO is concerned with providing

equal access to services and benefits for individuals with limited English proficiency. The MPO should be able to provide documentation such as public meeting agendas and minutes, and a discussion of how successfully related staff uses information with the described groups.

- Where appropriate, monitor the activities of member agencies and other transportation agencies in the region regarding compliance with Title VI, Limited English Proficiency, Americans with Disability Act and Environmental Justice requirements. This can be done through on-going reviews as part of oversight of documents, including agendas, minutes, technical memoranda, federal attendance at meetings, in desk reviews, and in discussions with local participants in the site visit.
- Evaluate the regional transportation system to ensure that services are accessible to person with disabilities.

Over the past few years, the U.S. Department of Transportation (DOT) has encouraged a proactive approach to the participation of protected groups and implementation of Title VI requirements. This approach is intended to ensure compliance with other related requirements, such as the National Environmental Policy Act.

Addressing requirements successfully requires several categories of actions:

- Establishing *goals and measurements* for substantiating compliance. These measurements should be used to verify that the multi-modal system access and mobility performance improvements in the Transportation Plan, TIP, and underlying planning process comply with Title VI and related requirements.
- The MPO must consider the needs of low-income and minority populations in the existing conditions analysis prepared as part of the transportation process. This information will provide the planning context for future transit and road projects.
- The MPO must have a public involvement process that proactively seeks out and addresses the needs of those traditionally underserved by existing transportation systems, including but not limited to low-income and minority households.
- The MPO has a role in public involvement, but must also *work with the MODOT, City Utilities, and Missouri State University* to carry out the metropolitan planning process, including public involvement.
- The *products of the transportation process*—Long Range Transportation Plan, TIP, and the UPWP must demonstrate consistency with Title VI and related requirements and principles.

TITLE VI/ADA COMPLAINT PROCEDURE

Submission of Complaint: Any person or group who feels that he or she, individually, or as a member of any class of persons, on the basis of race, color, national origin, age, sex, disability, religion, low-income status, or English proficiency has been unfairly deprived of benefit, or unduly burdened by the transportation planning process, or denied the benefits of, or subjected to discrimination caused by the MPO may file a written complaint with the OTO Title VI/ADA Coordinator. A sample Title VI/ADA complaint form may be downloaded from our website <https://www.ozarkstransportation.org/our-resources/civil-rights>. It is not required to use this form; a letter with the same information is sufficient to file a complaint. Such complaints must be filed within 180 calendar days after the date the person or group believes the discrimination or encumbrance occurred. Note: Upon request, assistance, in preparation of any necessary written material, will be provided to a person(s) who is unable to read or write. Complaints should be mailed or sent to the OTO Title VI/ADA Coordinator, 2208 W Chesterfield Blvd, Suite 101, Springfield, MO 65807.

Title VI/ADA general steps of the OTO complaint process:

1. Alleged act of discrimination
2. Formal complaint received and logged by OTO
3. Formal complaint review by OTO
4. OTO letter of response issued
5. Corrective action or closure letter issued

Alleged act of discrimination: If someone believes that OTO has discriminated their civil rights on the basis of race, color, national origin, age, disability, religion, sex or English proficiency, then that person may file a written complaint by following the Title VI/ADA Complaint Procedure.

Formal complaint reviewed and investigated by OTO or FHWA: Once the complaint is received, the OTO will review it to determine which agency has jurisdiction. The complainant will receive an acknowledgement letter informing which agency will investigate the complaint. If the complaint is related to a program or service through the Federal Highway Administration (FHWA), the complaint will be directly forwarded to Missouri Department of Transportation (MoDOT), which should forward the complaint to the State's FHWA Division Office, which should forward the complaint to the FHWA Headquarters Office of Civil Rights (HCR). HCR is responsible for conducting review and investigation of all FHWA-related complaints following FHWA guidance. More information on FHWA procedures and responsibilities can be found on FHWA's webpage: <https://highways.dot.gov/civil-rights/title-vi-civil-rights-act-1964-and-additional-nondiscrimination-requirements>. As outlined in the Collaboration with Other Agencies section, OTO will notify FHWA of all complaints received.

For non-FHWA related complaints, OTO will generally complete an investigation within 90 days from receipt of a completed complaint form. If it is determined that more time is needed to review or investigate the complaint, the OTO Executive Director will notify the complainant with an estimated time frame for completing the review.

The Title VI Coordinator shall meet with the complainant within 45 calendar days after receiving the official complaint to clarify any part of the official complaint, if needed. If additional information is needed, OTO will notify complainant via letter and the complainant has 10 business days from the date of letter to send requested information to the Title VI Coordinator. If the complainant fails to contact or

provide additional requested information within 10 business days, OTO can administratively close the case. A case can also be administratively closed if the complainant no longer wishes to pursue their case.

Corrective action or closure letter issued: If the Title VI Coordinator and the Executive Director concur there was no Title VI violation, a letter of closure will be issued summarizing the allegations and stating that there were no Title VI violations or, if a violation did occur then a letter of finding will be issued stating the corrective action. Either response will be notification that the complaint has been resolved and closed.

The complainant may request reconsideration in writing to the OTO Executive Director no later than 10 days of an issued response letter from the OTO. The Executive Director will accept or reject the request for reconsideration within 10 calendar days and notify the complainant of the decision.

The complainant may further appeal in writing a denied decision no later than 10 calendar days after an issued notification. All information will be presented to the OTO Board of Directors to decide whether they agree or disagree with the decision.

A dissatisfied complainant may also file a complaint with the State of Missouri Department of Transportation, Federal Highway Administration, or Federal Transit Administration no later than 180 days after the alleged date of discrimination.

Contact Information for MoDOT, FHWA, and FTA Civil Rights Offices		
MoDOT External Civil Rights Division Attn: Title VI Program Coordinator 1617 Missouri Blvd P.O. Box 270 Jefferson City, MO 65102	Federal Transit Administration Office of Civil Rights Attention: Complaint Team East Building, 5th Floor - TCR 1200 New Jersey Ave., SE Washington, DC 20590	Federal Highway Administration Office of Civil Rights 1200 New Jersey Avenue, SE 8 th Floor E81-105 Washington, DC 20590

Collaboration with Other Agencies: In the event a formal complaint is received, the OTO will prepare a written statement within 10 working days describing the complaint. The OTO will use the written statement to notify the agencies listed below and any local agencies affected. Up-to-date information will be uniformly shared with each agency during the complaint review process for non-FHWA related complaints. The OTO may request input or guidance from any of these agencies, if needed. Agencies may request more or less information during the steps of collaboration.

Ozarks Transportation Organization Title VI Coordinator 2208 W Chesterfield Blvd., Suite 101 Springfield, MO 65807 Phone: 417-865-3042 Fax: 417-862-6013 dknaut@ozarkstransporation.org	Missouri Department of Transportation External Civil Rights Title VI Coordinator 1617 Missouri Blvd. PO Box 270 Jefferson City, MO 65102-0270
Federal Highway Administration Missouri Division Civil Rights Specialist 3220 W Edgewood, Suite H Jefferson City, MO 65109	Federal Transit Administration Region 7 Regional Civil Rights Officer 901 Locust St., Suite 404 Kansas City, MO 64106

Steps to collaborate with above agencies for non-FHWA related complaints:

1. Notify agencies of complaint
2. Coordinate with other agencies as appropriate in the investigation efforts
3. Provide a copy of the Letter of Response/Corrective Action/Closure Letter to agencies
4. Provide a semi-annual report of all Title VI/ADA complaints to agencies, including FHWA-related complaints



OZARKS TRANSPORTATION ORGANIZATION
A METROPOLITAN PLANNING ORGANIZATION

Notifying the Public of Rights Under Title VI

Ozarks Transportation Organization (OTO) posts Title VI notices on our agency's website and in public areas of our agency.

Ozarks Transportation Organization (OTO) operates its programs and services without regard to race, color, or national origin, in accordance with Title VI of the Civil Rights Act of 1964.

To obtain additional information about your rights under Title VI, contact the Ozark Transportation Organization located at 2208 W Chesterfield Blvd. Suite 101 in Springfield MO 65807 per mail or via phone at (417) 865 3042.

If you believe you have been discriminated against on the basis of race, color, or national origin by the Ozarks Transportation Organization you may file a Title VI complaint by completing, signing, and submitting the agency's Title VI Complaint Form.

How to file a Title VI complaint with Ozarks Transportation Organization:

1. To obtain a Complaint Form from the Ozarks Transportation Organization contact Title VI Coordinator at 2208 W Chesterfield Blvd, Suite 101, Springfield MO 65807. To download instructions on how to file a complaint, or download a Title VI/ ADA Complaint Form, visit OTOs website at <https://www.ozarkstransportation.org/our-resources/civil-rights>
2. In addition to the complaint process at Ozarks Transportation Organization complaints may be filed directly with the Federal Transit Administration, Office of Civil Rights, Attention: Title VI Program Coordinator, East Building, 5th Floor-TCR, 1200 New Jersey Ave., SE, Washington DC 20590
3. Complaints must be filed within 180 days following the date of the alleged discriminatory occurrence and should contain as much detailed information about the alleged discrimination as possible.
4. The form must be signed and dated, and include your contact information.

If you need relay services please call the following numbers: 711 - Nationwide relay service; 1-800-735-2966 - Missouri TTY service; 1-800-735-0135 - Missouri voice carry-over service.

If information is needed in another language, contact 417-865-3042.

"Title VI of the Civil Rights Act of 1964, 42 U.S.C. 2000d et seq., and its implementing regulations provide that no person in the United States shall, on the grounds of race, color, or national origin, be excluded from participation in, be denied benefits of, or be otherwise subjected to discrimination under any program or activity that receives Federal financial assistance."

TITLE VI/ADA COMPLAINT FORM



OZARKS TRANSPORTATION ORGANIZATION
A METROPOLITAN PLANNING ORGANIZATION

The purpose of this form is to assist you in filling a complaint with the Ozarks Transportation Organization (OTO), the federally designated metropolitan planning organization (MPO) for the Springfield area, pursuant to nondiscrimination laws, rules, and regulations including, but limited to: Title VI of the Civil Rights Act of 1964 and Executive Order 13166 – Improving Access to Services for Persons with Limited English Proficiency, as well as Title II of the American with Disabilities Act (ADA) of 1991.

Please use this form if you or your group feels the actions of the MPO have negatively impacted or caused undue burden to either, but not limited to, a specific minority group, disabled individuals, lower-income population, individuals with limited English proficiency, or the traditionally underserved.

You are not required to use this form; a letter with the same information is sufficient to file a complaint.

This form is also available in Spanish and can be found on the OTO’s website at:
www.ozarkstransportation.org.

If you need assistance completing this form, please contact us by phone at 417-865-3042 or via email at dknaut@ozarkstransportation.org.

Complaints of discrimination MUST be filed within 180 calendar days of the date that the alleged discrimination occurred.

Section 1				
Name:				
Address:		City:	State:	Zip Code:
Home phone:		Work phone:		
Electronic mail (e-mail) address:				
Accessible format requirements?	Large print		Audiotape	
	TDD/TTY		other	

TITLE VI/ADA COMPLAINT FORM

Section 2			
Are you filing this complaint on your own behalf?	Yes*	No	
*If you answered "yes" to this question, go to Section 3			
If you answered "no", please provide the name, address, and relationship of the person for whom you are filing this complaint:	Name:		
	Address:		
	City:	State:	Zip Code:
	Telephone number or electronic mail (e-mail) address:		
	Relationship:		
Please explain why you have filed for a third party:			
Please confirm that you have obtained the permission of the aggrieved party if you are filing on behalf of a third party.	Yes, I have permission.	No, I do not have permission.	
Section 3			
I believe the discrimination I experienced was based on (check all that apply):			
Title VI		Other Federal Non-Discrimination Statutes	
Race	Color	National Origin	Gender Age Disability (Title II)
Where did the alleged discrimination take place?			
Date of Alleged Discrimination (Month, Day, Year):			
Explain as clearly as possible what happened and why you believe you were discriminated against. Describe all persons who were involved. Include the name and contact information of the person(s) who you believe discriminated against you (if known) as well as names and contact information of any witnesses. If more space is needed, please use a separate page, and attach it to this form.			
Name of agency complaint is against:			
Contact person:			

TITLE VI/ADA COMPLAINT FORM

Title:
Phone:
Explanation:
How can this/ these issue(s) be resolved to your satisfaction?
What is the most convenient time and place for us to contact you about this complaint?

TITLE VI/ADA COMPLAINT FORM

Section 4				
Have you filed this complaint with any other Federal, State, or local agency, or with any Federal or State Court?				
Yes		No		
If yes, check all that apply				
Federal Agency (List agency's name):		State Agency (Specify Agency):		County Court (Specify Court and County):
Federal Court (Please provide location):		State Court:		Local Agency (Specify Name):
If you answered "yes" above, please provide information about a contact person at the agency/ court where the complaint was filed:				
Name:		Title:		Agency:
Address:			City:	State:
				Zip Code:
Telephone number or electronic mail (e-mail) address:				
Section 5				
<p>You may attach any written materials or other information that you think are relevant to your complaint.</p> <p>By signing below you acknowledge that the information in this complaint is true and accurate to the best of your knowledge and belief.</p> <p>Signature and date required below:</p>				
Signature				Date
<p>Please feel free to add additional sheets to explain the present situation to us.</p> <p>Please mail the completed, signed Discrimination Complaint Form (please make one copy for your records) to:</p> <p>Ozarks Transportation Organization Title VI/ADA Coordinator 2208 West Chesterfield Blvd., Suite 101 Springfield, MO 65807 417-865-3042 (phone) 417-862-6013 (fax)</p>				

TITLE VI/ADA COMPLAINT FORM

You can use this page if you need additional space to provide more information requested on this form.

Appendix C: Title VI/ADA Complaint Procedures and Form in Spanish, including Title VI Public Notice



OZARKS TRANSPORTATION ORGANIZATION
A METROPOLITAN PLANNING ORGANIZATION

POLÍTICA Y PROCEDIMIENTO DE QUEJA TITULO VI DEL ADA

El Title VI, 42 U.S.C. § 2000d et seq., fue promulgado como parte de la Civil Rights Act (Ley de Derechos Civiles) de 1964. Prohíbe la discriminación por motivos de raza, color y origen étnico en programas y actividades que reciben asistencia financiera federal.

Dos Executive Orders (órdenes ejecutivas) y estatutos relacionados definen las poblaciones protegidas bajo el Title VI (Título VI). La Executive Order 12898 se refiere a la justicia ambiental para poblaciones minoritarias y de bajos recursos. La Executive Order 13166 se refiere a proporcionar igual acceso a servicios y beneficios para personas con dominio limitado del inglés.

La Ozarks Transportation Organization (OTO) (Organización de Transporte de los Ozarks) tiene establecido un procedimiento de quejas - Title VI/ADA Complaint Procedure, que describe un proceso para la resolución local de quejas del Title VI/ADA y es coherente con las pautas encontradas en el Chapter VII de la Federal Transit Administration Circular 4702.1B (de la administración federal de tránsito), con fecha del 1 de octubre de 2012. Si usted considera que la Metropolitan Planning Organization (MPO por sus siglas en inglés) (Organización de Planeación Metropolitana) ha discriminado sus derechos civiles por motivos de raza, color, origen étnico, edad, discapacidad, religión, sexo o dominio del inglés, puede presentar una queja por escrito siguiendo el procedimiento detallado a continuación bajo el Title VI/ADA Complaint Procedure (Procedimiento de Quejas de Title VI/ADA):

RESPONSABILIDADES DE LA OTO PARA EL Title VI/ADA

De conformidad con la Federal Law (Ley Federal), la Ozarks Transportation Organization será responsable de lo siguiente:

- Analizar datos regionales para identificar concentraciones de grupos étnicos minoritarios y de bajos recursos, así como de personas con dominio limitado del inglés dentro de la región. El compromiso del personal y los recursos financieros para este trabajo técnico pueden demostrarse en el Programa de Trabajo. El personal de la MPO puede explicar cómo se utilizan los recursos técnicos (modelos, Sistemas de Información Geográfica (GIS, por sus siglas en inglés), bases de datos y análisis, etc.) para la planificación y el análisis relacionados con el Title VI. La MPO podría ser requerida para discutir esto y cómo se utiliza la información técnica generada en la planeación.
- En caso necesario, proporcionar a las agencias miembros datos regionales que les ayuden a identificar grupos étnicos minoritarios y de bajos recursos en su subregión o área de servicio. El equipo podría discutir en qué medida esta información es útil y utilizada por las agencias participantes
- Establecer estándares, medidas y puntos de referencia apropiados, y analizar el proceso de transporte, el Transportation Improvement Program (Programa de Mejora del Transporte, TIP, por sus siglas en inglés) y otras acciones, planes e inversiones de la MPO para garantizar que

sean consistentes y no violen el Title VI de la Civil Rights Act (Ley de Derechos Civiles) y la Executive Order on Environmental Justice (Orden Ejecutiva sobre Justicia Ambiental). El esfuerzo en estas áreas podría ser demostrado en el Unified Planning Work Program (UPWP, por sus siglas en inglés) (Programa de Trabajo Unificado de Planeación), así como en el TIP, y en discusiones sobre cómo se utiliza este análisis en el proceso de planeación.

- Asegurar que los miembros de comunidades de bajos recursos y minorías, incluidos los gobiernos tribales indígenas, tengan amplias oportunidades para participar en el proceso de planeación del transporte regional. Esto incluye tomar medidas para eliminar obstáculos lingüísticos, de movilidad, temporales y otros que les permitan participar plenamente en el proceso. La MPO se preocupa por proporcionar igual acceso a servicios y beneficios para personas con dominio limitado del inglés. La MPO debería poder proporcionar documentación, como agendas y actas de reuniones públicas, y una discusión sobre cómo el personal relacionado utiliza exitosamente la información con los grupos descritos.
- Según sea el caso, supervisar las actividades de las agencias miembros y otras agencias de transporte en la región en relación con el cumplimiento del Title VI, el Limited English Proficiency (Dominio Limitado del Inglés), la Americans with Disability Act (Ley de Estadounidenses con Discapacidades) y los requisitos de Justicia Ambiental. Esto puede hacerse a través de revisiones continuas como parte de la supervisión de documentos, incluidas agendas, actas, memorandos técnicos, asistencia federal a reuniones, revisiones en el escritorio y discusiones con participantes locales en la visita al sitio.
- Evaluar el sistema de transporte regional para asegurar que los servicios sean accesibles para las personas con discapacidades.

En los últimos años, el U.S. Department of Transportation (DOT) (Departamento de Transporte de los Estados Unidos) ha fomentado un enfoque proactivo para la participación de grupos protegidos y la implementación de los requisitos del Title VI. Este enfoque tiene como objetivo garantizar el cumplimiento de otros requisitos relacionados, como la National Environmental Policy Act (Ley Nacional de Política Ambiental).

Cumplir exitosamente con los requisitos implica varias categorías de acciones:

- Establecimiento *de objetivos y medidas* para comprobar el cumplimiento. Estas medidas deberán utilizarse para verificar que las mejoras en el acceso y movilidad del sistema multimodal en el Plan de Transporte, el TIP y el proceso de planificación subyacente cumplan con el Title VI y los requisitos relacionados.
- La MPO deberá considerar las necesidades de las poblaciones de bajos recursos y minorías en el análisis de las condiciones existentes preparado como parte del proceso de transporte. Esta información proporcionará el contexto de planeación para futuros proyectos de tránsito y carreteras.
- La MPO deberá contar con un proceso de participación pública que busque de manera proactiva y aborde las necesidades de aquellos tradicionalmente desatendidos por los sistemas de transporte existentes, incluidos, entre otros, los hogares de bajos recursos y las minorías.
- La MPO tiene un papel en la participación pública, pero también deberá *trabajar con MODOT, City Utilities y la Missouri State University para llevar a cabo el proceso de planeación metropolitana*, incluida la participación pública.
- Los *productos del proceso de transporte*—Long Range Transportation Plan (Plan de Transporte a Largo Plazo), el TIP y el UPWP, deben demostrar consistencia con el Title VI y los requisitos y principios relacionados.

PROCEDIMIENTO DE QUEJA TITULO VI/ ADA

Presentación de Queja: Cualquier persona o grupo que sienta que él o ella, individualmente, o como miembro de cualquier clase de personas, por motivos de raza, color, origen étnico, edad, sexo, discapacidad, religión, condición de bajos recursos o dominio limitado del inglés, ha sido privado injustamente de beneficios, o cargado de manera indebida por el proceso de planeación del transporte, o le hayan sido negados los beneficios o haya sido objeto de discriminación causada por la MPO, podrá presentar una queja por escrito ante el OTO Title VI/ADA Coordinator (Coordinador de Title VI/ADA de la OTO). El formulario de queja de Title VI/ADA puede ser descargado a través de nuestro sitio web ozarkstransportation.org. Puede utilizar este formulario o enviar una carta que contenga la misma información. Las quejas deberán ser presentadas dentro de los 180 días calendario después de la fecha en que la persona o grupo considera que ocurrió la discriminación o la carga indebida. Nota: Bajo solicitud, le podrá ser proporcionada asistencia para la preparación de cualquier material por escrito necesario a aquellas persona(s) que no puedan leer o escribir. Las quejas deberán ser enviadas por correo o enviarse al OTO Title VI/ADA Coordinator, 2208 W Chesterfield Blvd, Suite 101, Springfield, MO 65807.

Pasos generales del proceso de queja de la OTO para el Title VI/ADA:

1. Presunto Acto de Discriminación
2. Queja formal recibida y registrada por la OTO
3. Revisión de la queja formal por la OTO
4. Emisión de la carta de respuesta de la OTO
5. Emisión de la carta de acción correctiva o cierre

Presunto Acto de Discriminación: Si alguien considera que la OTO, ha discriminado sus derechos civiles por motivos de raza, color, origen étnico, edad, discapacidad, religión, sexo o dominio del inglés, puede presentar una queja por escrito siguiendo el Title VI/ADA Complaint Procedure (Procedimiento de Quejas de Title VI/ADA).

Queja formal revisada e investigada por la OTO o la FHWA: Una vez recibida la queja, la OTO la revisará para determinar qué agencia tiene jurisdicción. El denunciante recibirá una carta de acuse de recibido informando qué agencia investigará la queja. Si la queja está relacionada con un programa o servicio de la Federal Highway Administration (FHWA) (Administración Federal de Carreteras), la queja se enviará directamente la Missouri Department of Transportation (MoDOT) (Departamento de Transporte de Missouri), el cual debería remitir la queja a la Oficina de la División de la FHWA del estado, que a su vez debería enviarla a la Oficina de Derechos Civiles (HCR) de la Sede de la FHWA. La HCR es responsable de llevar a cabo la revisión e investigación de todas las quejas relacionadas con la FHWA siguiendo las directrices de esta agencia. Puede encontrar más información sobre los procedimientos y responsabilidades de la FHWA en su página web: <https://highways.dot.gov/civil-rights/title-vi-civil-rights-act-1964-and-additional-nondiscrimination-requirements>. Como se describe en la sección de Colaboración con otras agencias, la OTO notificará a la FHWA sobre todas las quejas recibidas.

Para las quejas no relacionadas con la FHWA, la OTO generalmente llevará a cabo una investigación dentro de un plazo de 90 días a partir de la recepción del formulario de queja completo. En caso de determinar que se requiere más tiempo para revisar o investigar la queja, el Director Ejecutivo de la OTO notificará al denunciante con un plazo estimado para finalizar la revisión.

El Coordinador del Title VI deberá reunirse con el demandante en un plazo de 45 días calendario posteriores a la recepción de la queja formal para aclarar cualquier punto de la misma, si fuese necesario. En caso de requerir información adicional, la OTO notificará al demandante por escrito y el demandante tendrá entonces 10 días hábiles a partir de la fecha de la carta para enviar la información solicitada al Coordinador del Title VI. La OTO podrá cerrar administrativamente el caso si el demandante no se comunica con la oficina o no proporciona la información adicional solicitada dentro del plazo de 10 días hábiles. También se podrá cerrar un caso administrativamente si el demandante decide no continuar con su queja.

Emisión de la carta de acción correctiva o cierre: Si el Coordinador del Title VI y el Director Ejecutivo están de acuerdo en que no hubo violación del Title VI, se emitirá una carta de cierre en donde se resuman las acusaciones y declarando que no hubo violación del Title VI/ADA, o, en caso que efectivamente haya ocurrido una violación, se emitirá una carta de hallazgo estableciendo la acción correctiva. Cualquiera de las respuestas será una notificación de que la queja ha sido resuelta y cerrada.

El demandante podrá solicitar una reevaluación por escrito al OTO Executive Director (Director Ejecutivo de la OTO) a más tardar a los 10 días posteriores de haber recibido la carta de respuesta emitida por la OTO. El Director Ejecutivo podrá aceptar o rechazar la solicitud de reevaluación dentro de los 10 días calendario y notificará al demandante sobre su decisión.

El demandante podrá continuar apelando por escrito una decisión denegada a más tardar a los 10 días calendario posteriores a la recepción de la notificación emitida. Toda la información será presentada a la Junta Directiva de la OTO para decidir si están de acuerdo o en desacuerdo con la decisión.

Un demandante insatisfecho podrá también presentar una queja ante la Missouri Department of Transportation (Departamento de Transporte de Missouri) o la Federal Transit Administration (Administración Federal de Tránsito) o la Federal Highway Administration (Administración Federal de Carreteras) a más tardar a los 180 días después de la presunta fecha en que ocurrió la discriminación.

Información de contacto para las Oficinas de Derechos Civiles del MoDOT, FHWA y FTA		
MoDOT External Civil Rights Division Attn: Title VI Program Coordinator 1617 Missouri Blvd P.O. Box 270 Jefferson City, MO, 65102	Federal Transit Administration Office of Civil Rights Attn: Complaint Team East Building, 5th Floor - TCR 1200 New Jersey Ave., SE Washington, DC 20590	Federal Highway Administration Office of Civil Rights 1200 New Jersey Avenue, SE 8 th Floor E81-105 Washington, DC 20590

COLABORACIÓN CON OTRAS AGENCIAS

En caso de recibir una queja formal, la OTO deberá preparar una declaración por escrito en un plazo de 10 días hábiles para describir la queja. Esta declaración por escrito será utilizada para notificar a las agencias involucradas y a cualquier organismo local afectado. Durante el proceso de revisión de quejas no relacionadas con la FHWA, se compartirá información actualizada de manera uniforme con todas las agencias involucradas. La OTO podrá solicitar aportes o asesoramiento a cualquiera de estas agencias, en caso de ser necesario. Es importante tener en cuenta que las agencias podrán solicitar mayor o menor información durante las etapas de colaboración.

<p>Ozarks Transportation Organization Title VI Coordinator 2208 W Chesterfield Blvd., Suite 101 Springfield, MO 65807 Teléfono: 417-865-3042 Fax: 417-862-6013</p>	<p>Missouri Department of Transportation External Civil Rights Division Title VI Coordinator 1617 Missouri Blvd P.O. Box 270 Jefferson City, Mo 65102-0270</p>
<p>Federal Highway Administration Missouri Division Civil Right Specialist 3220 W. Edgewood, Suite H Jefferson City, Missouri 65109</p>	<p>Federal Transit Administration Region 7 Oficial Regional de Derechos Civiles 901 Locust Street Suite 404 Kansas City, Missouri 64106</p>

Pasos para colaborar con las agencias mencionadas:

1. Notificar a las agencias sobre la queja
2. Coordinarse con otras agencias según corresponda en los esfuerzos de investigación.
3. Proporcionar una copia de la Carta de Respuesta/ Acción Correctiva/ Carta de Cierre a las agencias.
4. Presentar un informe semestral de todas las quejas de Title VI/ADA a las agencias, incluidas las quejas relacionadas con la FHWA.



OZARKS TRANSPORTATION ORGANIZATION
A METROPOLITAN PLANNING ORGANIZATION

Notificación al Público sobre los Derechos bajo el Title VI

La Ozarks Transportation Organization (OTO) publica avisos del Title VI en el sitio web de nuestra agencia y en áreas públicas de nuestras instalaciones.

La Organización de Transporte de los Ozarks (OTO) opera sus programas y servicios sin importar raza, color o etnia, de conformidad con el Title VI de la Civil Rights Act de 1964.

Para obtener mayor información sobre sus derechos en relación con el Title VI, podrá comunicarse con la Organización de Transporte de los Ozarks ubicada en 2208 W Chesterfield Blvd. Suite 101 en Springfield MO 65807, por correo o por teléfono al (417) 865 3042.

Si usted considera que ha sido discriminado por motivos de raza, color o etnia por la Organización de Transporte de los Ozarks, puede presentar una queja bajo el Title VI llenando, firmando y enviando el Formulario de Queja del Title VI de la agencia.

Cómo presentar una queja bajo el Title VI ante la Ozarks Transportation Organization:

1. Para obtener un Formulario de Queja de la Ozarks Transportation Organization, comuníquese con el Title VI Coordinator, 2208 W Chesterfield Blvd, Suite 101, Springfield MO 65807. Para descargar las instrucciones sobre cómo presentar una queja o descargar un Title VI/ ADA Complaint Form (Formulario de Queja del Title VI/ADA), visite el sitio web de la OTO en <https://www.ozarkstransportation.org/our-resources/civil-rights>
2. Además del proceso de quejas en la Organización de Transporte de los Ozarks, las quejas podrán ser presentadas directamente ante la Federal Transit Administration (Administración Federal de Tránsito), Office of Civil Rights, Attn: Title VI Program Coordinator, East Building, 5th Floor-TCR, 1200 New Jersey Ave., SE, Washington DC 20590
3. Las quejas deberán ser presentadas dentro de los 180 días posteriores a la fecha de la presunta discriminación y deberán contener la mayor cantidad de información detallada posible sobre la misma.
4. El formulario deberá llevar firma y fecha, e incluir su información de contacto.

En caso de requerir servicios de retransmisión, es necesario llamar a los siguientes números: 711 - Servicio de retransmisión a nivel nacional; 1-800-735-2966 - Servicio TTY de Missouri; 1-800-735-0135 - Servicio de transmisión de voz de Missouri.

En caso de requerir información en otro idioma, puede comunicarse al 417-865-3042.

“El Title VI of the Civil Rights Act of 1964, 42 U.S.C. 2000d et seq., así como las disposiciones para su implementación, establecen que ninguna persona en los Estados Unidos podrá, por motivos de raza, color u origen étnico, ser excluida de la participación en, serle negados los beneficios de, o ser de otra manera objeto de discriminación bajo cualquier programa o actividad que reciba asistencia financiera federal.”

Formulario de Queja del Title VI/ ADA



OZARKS TRANSPORTATION ORGANIZATION
A METROPOLITAN PLANNING ORGANIZATION

El propósito de este formulario es ayudarlo a presentar una queja ante la Ozarks Transportation Organization (Organización de Transporte de los Ozarks o OTO, por sus siglas en inglés), la organización de planificación metropolitana (MPO, por sus siglas en inglés) designada por el gobierno federal para el área de Springfield, de conformidad con las leyes, reglas y regulaciones antidiscriminatorias, incluidas, más no limitativas a: El Title VI de la Ley de Derechos Civiles de 1964 y la Executive Order 13166 (Orden Ejecutiva 13166) - Para la Mejora del Acceso a los Servicios para Personas con Dominio Limitado del Inglés, así como el Title II de la American with Disabilities Act (Ley de Estadounidenses con Discapacidades) (ADA, por sus siglas en inglés) de 1991.

Utilice este formulario si usted o su grupo sienten que las acciones de la MPO han tenido un impacto negativo o han causado una carga indebida para, entre otros, un grupo étnico minoritario, personas con discapacidad, población de bajos recursos, personas con dominio limitado del inglés o los tradicionalmente marginados.

Puede utilizar este formulario o enviar una carta que contenga la misma información.

Este formulario está disponible en español y podrá encontrarlo en el sitio web de la OTO en: www.ozarkstransportation.org.

En caso de requerir ayuda para llenar este formulario, comuníquese con nosotros al teléfono 417-865-3042 o por correo electrónico a dknaut@ozarkstransportation.org.

Las quejas por discriminación DEBERAN presentarse dentro de los 180 días calendario a partir de la fecha en la que ocurrió dicha discriminación.

Sección 1				
Nombre:				
Dirección:		Ciudad:	Estado:	Código Postal:
Teléfono de casa:		Teléfono del trabajo:		
Correo electrónico:				
Requisitos de formato para ser mayor accesibilidad	Tamaño grande de letra		Cinta de audio	
	TDD/TTY		otro	

Formulario de Queja del Title VI/ ADA

Sección 2			
¿Está presentando esta queja en calidad personal?	Si*	No	
*En caso de haber respondido que “si” a esta pregunta, vaya a la Sección 3.			
Si respondió “No”, proporcione el nombre, dirección y relación con la persona para quien está presentando esta queja:	Nombre:		
	Dirección:		
	Ciudad:	Estado:	Código Postal:
	Número de Teléfono o Correo electrónico:		
	Parentesco:		
Explique por qué está presentando una queja a nombre de un tercero:			
Confirme si tiene autorización de la persona agraviada en caso de estar presentado esta queja a nombre de un tercero.	Si, tengo autorización.	No, no tengo autorización.	
Sección 3			
Considero que la discriminación que experimenté está basada en (marque todas las opciones que correspondan):			
Title VI	Otros Estatutos Federales de No Discriminación		
Raza Color Origen Étnico	Género	Edad Discapacidad (Title II)	
¿Dónde ocurrió la presunta discriminación?			
Fecha en la que ocurrió la presunta discriminación (Mes, Día, Año):			
Explique lo más claramente posible lo que sucedió y por qué cree que fue discriminado. Describa a todas las personas involucradas. Incluya el nombre y la información de contacto de la(s) persona(s) que considera que lo discriminaron (en caso de conocerlos), así como los nombres e información de contacto de cualquier testigo. Si necesita más espacio, utilice una página adicional y adjúntela a este formulario.			
Nombre de la agencia contra la que se presenta la queja:			
Persona de Contacto:			

Formulario de Queja del Title VI/ ADA

Título:

Teléfono:

Explicación:

¿Cómo puede resolverse este asunto para su satisfacción?

¿Cuál es el momento y lugar más conveniente para que nos pongamos en contacto con usted en relación a esta queja?

Formulario de Queja del Title VI/ ADA

Sección 4				
¿Ha presentado esta queja ante alguna otra Agencia Federal, Estatal o local, o ante algún Juzgado Federal o Estatal?				
Si		No		
En caso afirmativo, marque todas las opciones que correspondan:				
Agencia Federal (Indique el nombre de la agencia):	Agencia Estatal (Especifique la Agencia):	Juzgado del Condado (Especifique Juzgado y Condado):		
Juzgado Federal (Proporcione la ubicación):	Juzgado Estatal:	Agencia Local (Especifique el Nombre):		
En caso de haber respondido "sí" anteriormente, proporcione información sobre una persona de contacto en la agencia/tribunal donde se presentó la queja:				
Nombre:	Título:	Agencia:		
Dirección:	Ciudad:	Estado:	Código Postal:	
Número de Teléfono o Correo electrónico:				
Sección 5				
<p>Puede adjuntar cualquier material escrito o cualquier información que considere relevante para su queja.</p> <p>Al firmar a continuación, usted reconoce que la información en esta queja es verdadera y precisa a su mejor entendimiento.</p> <p>Se requiere su firma y fecha a continuación:</p>				
Firma:			Fecha:	
<p>Puede incluir las hojas adicionales que considere necesarias para describir la situación actual</p> <p>Envíe el Discrimination Complaint Form (Formulario de Queja por Discriminación) completado y firmado (haga una copia para sus registros) a:</p> <p>Ozarks Transportation Organization Title VI/ADA Coordinator 2208 West Chesterfield Blvd., Suite 101 Springfield, MO 65807 417-865-3042 (teléfono) 417-862-6013 (fax)</p>				

Formulario de Queja del Title VI/ ADA

Puede utilizar esta página si requiere espacio adicional para proporcionar más información solicitada en este formulario.

Appendix D: ADA Public Notice



OZARKS TRANSPORTATION ORGANIZATION
A METROPOLITAN PLANNING ORGANIZATION

Notifying the Public of Rights Under American with Disabilities Act (ADA)

ADA Policy Statement

The Ozarks Transportation Organization is committed to ensuring that its services are accessible to all persons and strictly prohibits discrimination based on disability. If you have a complaint about the accessibility of our services or believe you have been discriminated against because of your disability, you can file a complaint.

ADA Complaint Procedures

If you have a complaint about the accessibility of our services or believe you have been discriminated against because of your disability, you can file a complaint. Please provide all facts and circumstances surrounding your issue or complaint so we can fully investigate the incident.

How do you file a complaint?

You can download and use our Title VI/ ADA complaint form at <https://www.ozarkstransportation.org/our-resources/civil-rights> or request a copy of the form by contacting Ozark Transportation Organization located at 2208 W Chesterfield Blvd. Suite 101 in Springfield MO 65807 per mail or via phone at (417) 865 3042.

You may file a signed, dated and written complaint no more than 180 days from the date of the alleged incident.

Please submit your complaint form to address listed below:

Ozarks Transportation Organization
Title VI/ ADA Coordinator
2208 W Chesterfield Ave, Suite 101
Springfield, MO 65807

Do you need complaint assistance?

If you are unable to complete a written complaint due to a disability or if information is needed in another format, such as braille or large print, we can assist you. Please contact us at (417) 865 3042 or dknaut@ozarkstransportation.com.

If you need relay services please call the following numbers: 711 - Nationwide relay service; 1-800-735-2966 - Missouri TTY service; 1-800-735-0135 - Missouri voice carry-over service.

If information is needed in another language, contact 417-865-3042.

En caso de requerir información en otro idioma, puede comunicarse al 417-865-3042.

"Título VI de la Ley de Derechos Civiles de 1964, 42 U.S.C 2000d y ss., y su reglamentaciones implementadas establecen que ninguna persona en los Estados Unidos será, por motivos de raza, color o origen nacional, excluida de participar en, negado los beneficios de, o de otra manera sujeto a discriminación bajo cualquier programa o actividad que recibe asistencia financiera federal."

Appendix E: Public Participation Plan

PUBLIC PARTICIPATION PLAN 2023



The Ozarks Transportation Organization

A Metropolitan Planning Organization

Approved by the Board of Directors July 20, 2023

This report was prepared in cooperation with the USDOT, including FHWA and FTA, as well as the Missouri Department of Transportation. The opinions, findings, and conclusions expressed in this publication are those of the authors and not necessarily those of the Missouri Highways and Transportation Commission, the Federal Highway Administration, or the Federal Transit Administration.

Page Intentionally left blank

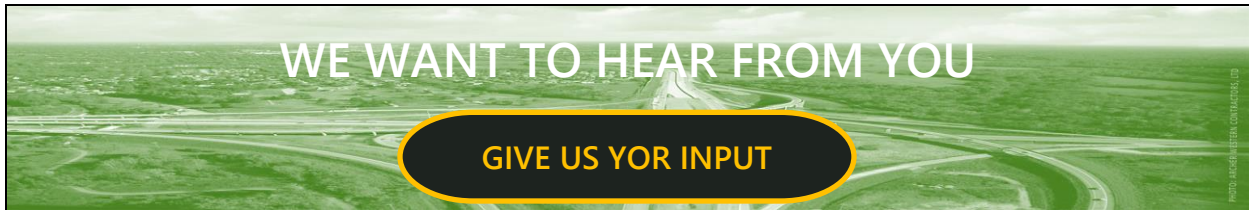

Our goal at the Ozarks Transportation Organization is to have meaningful involvement in the transportation planning process. We encourage you to voice your ideas and opinions about specific actions or transportation issues at any time. Your comments are reviewed by staff and included in agendas for consideration by our Board of Directors and appropriate committees. Here is how you can join the conversation via the linked buttons to the OTO website:

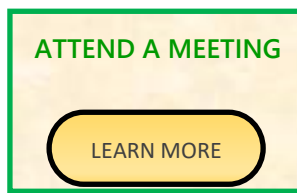
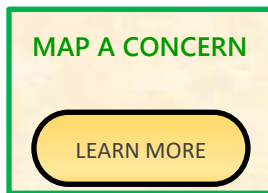

WHAT WE DO WITH YOUR INPUT

The OTO solicits public comments for updates and major amendments to all the requisite plans and key decision points in the planning process. Public comments for major plans are summarized with an explanation of how they were integrated into the final version. All comments, opinions, or suggestions are presented to our Board of Directors to consider before they make any final decisions. In addition, public concerns are shared with MoDOT and local governments as appropriate. Meaningful public involvement is key to developing a sound and efficient transportation system that works for the people it serves.

Follow us on social media to stay up to date on what we are planning and keep us informed of your ideas and opinions.



Executive Summary

The OTO 2023 Public Participation Plan (PPP) is an update of the 2020 PPP. The OTO updates its PPP every three years to ensure that we are employing the latest techniques and utilizing the most up-to-date resources to keep the public involved with and informed of our planning activities. Several revisions have been made to the PPP that was approved by the OTO Board of Directors on August 20, 2020. Updates include:

- A section describing Virtual Public Engagement has been added to the Methods of Engagement section of the plan;
- Policy objectives have been reformatted and included in a new section with the same title;
- Content throughout the plan was updated in consultation with [Promising Practices for Meaningful Public Involvement in Transportation Decision-Making](#), U.S. Department of Transportation, 2022 and Transportation Research Board's National Cooperative Highway Research Program (NCHRP) Report 710: [Practical Approaches for Involving Traditionally Underserved Populations in Transportation Decision-making](#), 2012;
- The OTO has developed a supporting tool, a [Social Equity Index](#) was developed using GIS software and U.S. Census Bureau data as a first step in involving traditionally underserved populations by identifying equity areas for targeted engagement.
- Results from the 2023 Interested Parties Public Participation Survey have been added as Appendix A.

Ozarks Transportation Organization MPO Study Area

Approved by the Governor of Missouri 2/8/2002

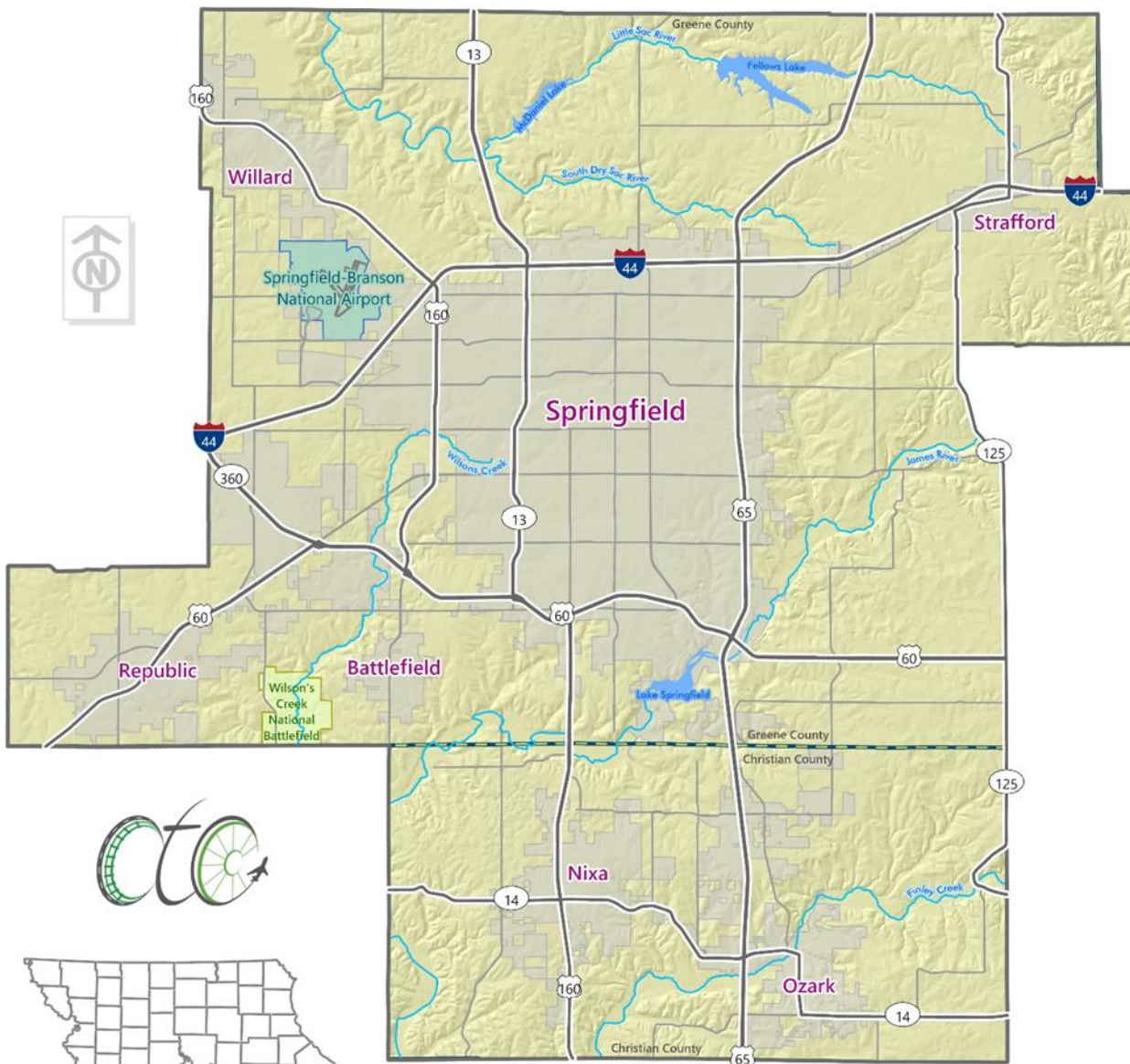

- Major Roadways
- Arterial Roadways
- Rivers
- County Line
- Cities
- Lakes

Table of Contents

Executive Summary i

Introduction 1

Public Participation Goals 4

Policy Objectives 5

Methods of Community Engagement 7

Requirements for Planning Activities 11

 Long Range Transportation Plan 12

 Transportation Improvement Program 14

 Unified Planning Work Program 20

 Public Participation Plan 20

 Other Plans & Studies 21

 Public Meetings 22

Public Participation Process 24

 Inform 25

 Consult 26

 Collaborate 27

Appendix A: Interested Party Survey Results 28

Figure 1: Public Comment Periods for Specific Plans and Purposes 22

Introduction

The Ozarks Transportation Organization (OTO) is the federally designated Metropolitan Planning Organization (MPO) serving several communities in the Springfield, Missouri metro area including unincorporated parts of Christian and Greene counties.

As an MPO, the OTO conducts regional transportation planning and project programming within its study area. The mission of the OTO is: *To provide a forum for cooperative decision-making in support of an excellent regional transportation system.* The OTO serves as a forum for cooperative transportation decision-making by state and local officials and other interested parties in accordance with a process that is **comprehensive**, **cooperative**, and **continuous**. This process covers federal aid surface transportation projects and other regionally significant projects. The OTO Board of Directors includes local elected and appointed representatives from Christian and Greene counties, as well as the cities of Battlefield, Nixa, Ozark, Republic, Springfield, Strafford, and Willard.

The OTO is responsible for four major transportation plans and programs: [Long-Range Transportation Plan](#) (LRTP); [Transportation Improvement Program](#) (TIP); [Unified Planning Work Program](#) (UPWP); and [Public Participation Plan](#) (PPP). In addition, the OTO is responsible for preparing [other transportation plans and studies](#) as needed.

The OTO must adopt an LRTP covering at least 20 years and update it every five years. The TIP selects projects from the LRTP to fund for construction and must also be adopted by the Board of Directors. No federal transportation money can be spent on a project unless it is in the LRTP and the TIP. In addition to the LRTP and TIP, the OTO is required to prepare a Unified Planning Work Program (UPWP), and other plans and studies including a plan for public participation. The Public Participation Plan (PPP) documents policies and processes implemented by the OTO to provide a path for meaningful involvement of individuals, public agencies, and other interested parties in OTO's transportation planning processes.

The OTO must comply with Federal Highway Administration (FHWA) requirements that MPOs, "*Include a proactive public involvement process that provides complete information, timely public notice, full public access to key decisions, and supports early and continuing involvement of the public in developing plans and TIPs.*" (23 CFR §450.316)

To achieve full public access, the OTO adheres to other regulations that require MPOs be proactive in involving underserved populations in the planning process. Traditionally underserved can be defined as low-income and minority populations including Hispanics/Latinos, African Americans/Blacks, Asian Americans, Native American/ Alaskan Natives and Native Hawaiians, and Pacific Islanders. Populations recognized in Title VI and other civil rights legislation, executive orders, and transportation legislation are those with limited English proficiency, low-literacy populations, seniors, persons with disabilities, and transit-dependent populations are considered underserved groups in the transportation decision-making process.

- Title VI of the Civil Rights Act of 1964 prohibits discrimination based on race, color, and national origin. Title VI applies to all organizations that receive federal funding;
- Section 504 of the Rehabilitation Act of 1973 and The Americans with Disabilities Act of 1991 prohibit discrimination based on a disability by public and private sector parties;
- In 1994, Executive Order 12898, required federal agencies make environmental justice part of their mission by identifying and addressing, disproportionately high and adverse effects of its programs, policies, and activities on minority and low-income populations;
- In 2000, Executive Order 13166 gave Title VI discrimination protection to people with Limited English Proficiency (LEP).

We at the OTO believe that it is important to give people the opportunity to have a meaningful impact on the development of plans and programs that affect them. The PPP provides direction and documents the process for inclusive community engagement for the OTO transportation planning activities. In addition, the PPP is how the OTO will maintain compliance with federal regulations and measure the effectiveness of procedures and strategies aimed at supporting early and continuous involvement of the public.

Public involvement is an ongoing effort at the OTO. Whether it is a component of a major plan update, posting agendas for committee meetings, reviewing roadway concerns received from the citizens, or sending press releases to local media to notify the press and citizens of studies and proposed projects. As such, all staff members must have the capacity to effectively communicate with individuals and stakeholders and reduce barriers to meaningful public engagement. This plan document is intended to be a useful guide to all OTO staff members no matter their role in the planning process.

The remainder of the plan includes goals and policy objectives to ensure effective public involvement for the planning activities at the OTO are in place and to hold ourselves accountable. Additional sections of the plan include methods for communicating with and gathering input from the public, public participation requirements for specific plans and activities required of MPOs, and finally, the processes and workflows the OTO employs are illustrated to provide structure and continuity for public engagement in the various activities of our transportation planning efforts.

Public Participation Goals

At the OTO MPO, the level of public participation required for activities in the planning process changes according to what is to be accomplished. The International Association for Public Participation developed a spectrum for increasing levels of public impact. The table below describes the spectrum which helps define the public’s role and engagement in the transportation planning process.

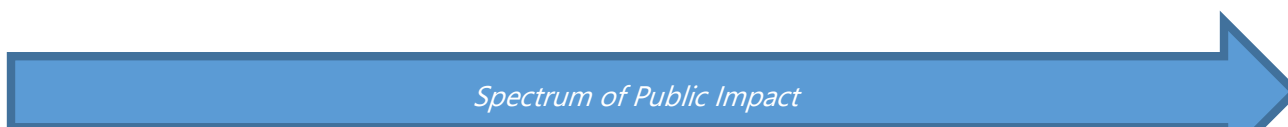

	Inform	Consult	Involve	Collaborate	Empower
Goal	To provide the public with balanced and objective information to assist them in understanding the problems, alternatives, and/or solutions.	To obtain public feedback on analysis, alternatives, and/or decisions.	To work directly with the public throughout the process to ensure that public issues and concerns are consistently understood and considered.	To partner with the public in each aspect of the decision including the development of alternatives and the identification of the preferred solution.	To place the final decision-making in the hands of the Public

Adapted from the International Association for Public Participation "Spectrum of Participation" www.iap2.org.

The progressive spectrum of public impact applies to the different work products and day-to-day engagement activities at the OTO. These categories and goals are aligned with various planning activities, tools, and workflows to ensure that early and continuous public participation is achieved in support of the OTO mission. More detail is provided in the "Planning Process" section of the plan.

Policy Objectives

The U.S. Department of Transportation defines meaningful public involvement as, "...a process that proactively seeks full representation from the community, considers public comments and feedback, and acts on that feedback to incorporate into a project, program, or plan." To ensure that individuals and communities have an equitable voice in transportation decision-making processes, practitioners should address barriers to meaningful public involvement, especially in historically underserved communities. To remove barriers to meaningful public participation, the OTO will adhere to the following set of public participation policy objectives:

- The OTO will give the public a reasonable opportunity to participate in planning activities and allow time for public review and comment at key decision points, including, but not limited to, approval of the LRTP, TIP, and other appropriate transportation plans and projects.
- The OTO will demonstrate explicit consideration and response to public input received during the development of the metropolitan transportation plan and the TIP.
- The OTO will provide reasonable public access to timely information, plans, reports, and studies and maintain open channels of communication for citizens to comment or report a concern.
- The OTO will develop planning material that is easily understood and visually engaging and strive to ensure all citizens have the information necessary to deliver informed input.

- The OTO will prepare visualizations of transportation issues including charts, graphs, aerial photos, maps, analyses, physical models, and computer simulations with the public in mind.
- Making public information (technical information and meeting notices) available in electronically accessible formats and means on the OTO website.
- The OTO will strive to ensure that when conducting public meetings where matters related to transportation programs are being considered, they are connected to transit and meet Americans with Disabilities Act requirements.
- The OTO will strive to demonstrate that public concerns are addressed, questions are answered, and comments are taken into consideration. Upon receiving public comments, the OTO will respond in a timely manner and provide copies of comments to appropriate boards, committees, and related agencies.
- The OTO will maintain an up-to-date database of contacts to ensure that all interested parties have reasonable opportunities to comment on the transportation planning process and products.
- The OTO will seek out input from and consider the needs of those traditionally underserved by existing transportation systems, such as low-income and minority households, limited English-speaking persons, and persons with disabilities who may face challenges accessing employment and other services.

Methods of Community Engagement

The Resources listed here are the methods the OTO uses to engage and communicate with the individuals and stakeholders we serve.

Virtual Public Involvement

The OTO employs virtual public involvement tools that make public participation more convenient and affordable than in-person public meetings. In-person meetings may conflict with work and school schedules or are less accessible to individuals that rely on transit or have disabilities. In 2020, the OTO began utilizing Facebook to live broadcast Technical Planning Committee and Board of Director meetings moderating and communicating comments in real-time due to COVID-19 stay-at-home orders. The broadcasts remain available on the OTO's Facebook page. This example illustrates how virtual public involvement has emerged to provide increased transparency and access to transportation planning activities at the OTO. While there are many methods employed at the OTO to disseminate information and gather input from the public and other interested parties, OTO staff are always looking for new and innovative software and apps to enhance and improve public engagement.

[The OTO Website](#)

The OTO website was redesigned in 2019. The new design provides information about upcoming meetings and agendas, recent reports, maps, and information about OTO policies. Work products, such as the PPP, UPWP, TIP, and LRTP are available on the site. The site also features an "About Us" page which contains information regarding "What is an MPO?" The site also serves as the domain for staff email accounts along with a comment email account to collect public input and feedback. The comment email is monitored by the OTO's planners and administrative staff. The comment account also receives automated notifications when comments are submitted on other web-based public input tools. In addition, the comment account is the primary account for sending

press releases, news, announcements, and agendas to the press, interested parties, and committees.

["Give Us Your Input"](#)

This is a page on the OTO website where the public can map a concern, leave a comment, access surveys, and learn about current planning activities and meeting dates. Notifications are sent to the comment email when comments are submitted. In addition, a discussion board has been embedded on this page where people can leave general comments for discussion moderated by OTO staff.

[News & Updates](#)

This is another component of the "Give Us Your Input" page on the OTO website. News & Updates is a blog post where the OTO staff can post information and announcements to which the public are directed to add a comment or a question.

[Interactive TIP Tool](#)

This is a web-based service that helps individuals find information about transportation projects planned for the next four years in the metro area. The tool allows users to search for project information and can be accessed from the TIP page on the OTO website. Using this tool, the TIP can be searched by project name, location or agency, and TIP number. The tool also features a map viewer for projects.

[The OTO Logo](#)

The OTO logo is prominently featured on all work products and correspondence. The logo helps the public recognize documents and activities associated with the OTO. This allows individuals to identify OTO work products and become familiar with its role in the region.

Social Media

[Facebook](#) and [Twitter](#) are used to announce meetings and events. Posts provide the opportunity to share links to pertinent information and survey sites. Social media platforms can also invite public comments and participation on the sites themselves.

ArcGIS Online Organization

The OTO publishes interactive web maps and apps through its ArcGIS Online Organization account. A [base map](#) consisting of layers for the transportation network, including sidewalks, trails, transit routes, and roads is available from the OTO website. Viewers can access roadway attributes for volume, capacity, peak hour travel speeds, etc. Natural features and land use information is also included in the map. Other applications include the OTO Equity Index. [The Equity Index app](#) includes American Community Survey data for 13 classes of traditionally underrepresented, transportation disadvantaged, and vulnerable populations.

OTO Contacts Database

The OTO maintains a comprehensive database of businesses, governmental agencies, community-based organizations, and other interested parties. The database includes committee membership, mailing information, phone numbers, email addresses and websites. The database is used for maintaining up-to-date contact information for committee membership, special interest groups, Disadvantaged Business Enterprises (DBE), as well as minority and low-income groups. The database is used for meeting and survey announcements as well as other project specific notifications.

Press Releases

Formal press releases are sent to local media contacts to announce upcoming meetings, comment periods for plan documents, and to provide information on specific issues being considered by the OTO or the OTO committees.

Newspaper Ads

Press releases may result in media coverage of the OTO activities but in most cases, they do not guarantee publication of information. Thus, the OTO purchases legal advertisements for announcements of comment periods for some planning documents. These legal ads serve to document compliance with the required comment period length for specific plans and plan/TIP amendments. When seeking public input for LRTP updates and the annual TIP process the OTO has purchased regular ad space in the print editions of the *Springfield News-Leader* and the *Christian County Headliner*. Additionally, the OTO reviews and considers publications in circulation at the time an ad is needed.

Surveys

The OTO uses web-based applications to generate electronic surveys. Hyperlinks to the survey are then disseminated via email, social media, press releases, and the OTO website. Hard copies are also produced and distributed at public meetings, community events, and the OTO office. In addition, post card mailings are used to publicize surveys and comment periods and include QR codes for mobile devices.

Public Meetings/Community Events

Public meetings are generally open and informal, with project team members interacting with the public on a one-on-one basis. Brochures and fact sheets may be provided at these meetings. The OTO may coordinate with other local agencies to be on hand to supply information and support. Informational tables at community events where transportation issues are not the focus are ways to solicit comment from individuals who are not usually involved in the transportation planning process.

Posters and Flyers

Posters and flyers are used to announce meetings and events and are distributed to public places such as City Halls, libraries, community centers, City Utilities buses and City Utilities bus transfer stations for display. Posters and flyers can be used to reach a larger audience than other notification methods.

Requirements for Planning Activities

There are specific plans that reflect the core functions of the OTO MPO. The LRTP, TIP, UPWP, and PPP comprise the core plans of the OTO. Participation processes are identified for each of these plans. Public participation strategies for other plans and studies are also addressed.

This section of the plan defines how the OTO provides for individuals and interested parties to be involved in the planning process. Interested parties are defined in 23 CFR § 450.316. Those that are applicable to the OTO MPO include:

- Elected officials;
- Local government staff;
- Transportation agencies (airport, transit, etc.);
- Local media (TV, radio, print, etc.);
- Civic groups;
- Special interest groups;
- Libraries (for public display);
- Federal, state, and local agencies responsible for land-use management, natural resources, environmental protection, conservation, historic preservation, and other environmental issues;
- Parties that have an interest in the planning and development of the transportation network including affected public agencies in the OTO planning area;
- Private freight shippers;
- Representatives of public transportation employees;
- Providers of freight transportation services;

- Private providers of transportation, including intercity bus operators and employer-based commuting programs;
- Representatives of users of public transportation;
- Representatives of users of pedestrian walkways and bicycle transportation facilities;
- Representatives of people with disabilities;
- Members of minority populations;
- Representatives of Limited English Proficiency (LEP) populations;
- Public school district representatives within the OTO planning area;
- Representatives of colleges and universities; and
- Representatives of large employers.

[Long-Range Transportation Plan](#)

The LRTP is essential in the development of a sound transportation network. Although long-range in scope, the plan provides direction and sets policies for day-to-day decision making. The LRTP builds on past transportation planning conducted by the OTO. All transportation modes including passenger air travel and freight movement are discussed in the document. The plan advocates for transportation policies and strategies developed via public involvement and assists in prioritizing transportation improvements over the next 25 to 30 years.

A specific public participation plan will be written to outline the public participation process at the outset of LRTP updates. The process for LRTP updates will use nearly the full range of the participation techniques employed by the OTO. A series of public meetings will be held throughout the region for each complete update. Events will be publicized using display advertisements in the *Springfield News-Leader* and other community newspapers. Opportunities for public involvement do not stop with the adoption of the Long-Range Transportation Plan. Although the LRTP must be completely updated at least every five years while in Environmental Protection Agency (EPA) air

quality attainment (four years when in non-attainment), amendments are periodically made to the LRTP as new projects, funding, or programs arise.

Amendments to the LRTP require a 15-day public notice and comment period prior to consideration by the OTO Board of Directors. Only chapters containing the proposed amendments are presented for public comment and approval.

Revisions to the LRTP Requiring Amendments:

- Addition or deletion of any project (except as noted in the Administrative Modifications section below);
- Substantial changes to the scope of a project (e.g., changing the type of project such as rehabilitation to expansion);
- Moving a project between the unconstrained and constrained lists
- Changes to the Major Thoroughfare Plan;
- Increases to a project's total cost estimate greater than 25 percent (or any amount greater than \$2,000,000);
- Changes in the termini of a capacity project of any length or any project in which the total length increases by more than ¼-mile.

Notice of Administrative Modifications, which are approved by staff, will be provided to the Board of Directors, MoDOT, and U.S. DOT. Administrative modification is a revision that includes minor changes to project/project phase costs, minor changes to funding sources of previously included projects, and minor changes to project/project phase initiation dates. An administrative modification does not require public review and comment, a re-demonstration of fiscal constraint, or a conformity determination.

Revisions to the LRTP Allowed as Administrative Modifications:

- Increases in a project's cost estimate less than 25 percent (up to \$2,000,000);
- Minor changes to the scope of a project;
- Minor increases to the termini of a non-capacity project (no more than ¼-mile);
- Moving a project to another time band, provided fiscal constraint is maintained;

- Adding a project to the unconstrained list;
- Technical corrections.

Transportation Improvement Program

The TIP is the short-range capital improvement program for the transportation system within the OTO study area. The TIP is a financially constrained four-year program outlining the most immediate implementation priorities for transportation projects and is updated annually. The TIP serves to program the expenditure of federal, state, and local transportation funds. To receive federal highway or transit funds a project must be included in the TIP. The TIP, as approved by the Board of Directors and the Missouri Department of Transportation, constitutes the selection document for project implementation. The first year of projects in the TIP represent the agreed list of projects eligible for implementation.

The OTO consults with all city and county governments within its study area during the annual TIP development process. The projects submitted by local governments are all part of their respective Capital Improvement Programs (CIP) where required. When developing the TIP, the OTO is required to consult with (1) agencies and officials responsible for other planning activities within the planning area, (2) recipients of assistance under title 49 U.S.C. Chapter 53, (3) government agencies and non-profit organizations (including representatives of the agencies and organizations) that receive Federal assistance from a source other than the U.S. Department of Transportation to provide non-emergency transportation services, and (4) recipients of assistance under 23 U.S.C. 204, and this process shall be documented in the intra-agency memorandum of understanding.

Depending on their area of concern, the following boards hold public hearings on the proposed projects: Airport Board; Park Board; and Planning and Zoning Commission/Board. Other required agencies that are consulted during the TIP development process include:

[City Utilities of Springfield](#) - In January of 2015, CU Transit and the OTO executed a memorandum of understanding (MOU) wherein, CU agreed to rely on the locally adopted

public participation process requirements for the TIP as outlined in the PPP in lieu of the process required to develop its Program of Projects (POP). Per the MOU with CU, the OTO public participation process for the TIP satisfies CU's public participation process for the POP and has agreed to the following:

- The OTO will be responsible to conduct the project selection process and to publish the annual Program of Projects for the FTA 5307 and 5339 programs;
- The OTO will conduct the public participation process for the Springfield Urbanized Area for the FTA 5307 and 5339 programs;
- The OTO's public participation plan should state that the OTO's public participation process satisfies CU's public participation process;
- CU will assist the OTO with the public involvement process by allowing notices for public input opportunities to be placed in CU buses and facilities at no charge to the OTO;
- CU will rely on the OTO's public involvement process for the TIP and requires public notices be published annually by the OTO. If the proposed POP is not amended, the OTO must include a statement that the proposed program will be the final program, unless amended, and satisfies the requirements regarding the final POP;
- The OTO's public notice for the TIP must have an explicit statement that public notice of public involvement activities and time established for public review of and comments on the TIP will satisfy the POP requirements;
- CU will rely on the public involvement process for the TIP conducted by the OTO to satisfy Section 5307 and 5339 public involvement requirements for the POP;
- CU will report performance measure indicators to the OTO for reporting to the USDOT and informing the public of the improved performance of the transportation system resulting from federal investment.

The OTO advertises City Utilities' POP each year in the *Springfield News-Leader*. A public hearing is required prior to implementing either an increase in Transit fares or a significant reduction in service. A significant reduction in service is defined by the following criteria:

- A decrease of 25 percent or more in the revenue miles of route, either at one time or cumulative during any twelve-month period; or
- An increase in headways for a route of more than 15 minutes; or
- A re-routing that will last more than 180 days and decrease the revenue miles of a route by 25 percent or more.

[Missouri State University](#) - MSU utilizes the Transit Shuttle Advisory Committee for public involvement in the selection of projects to be included in the TIP. This committee includes representatives of the student body, faculty, administration, and transit operations.

[OATS Transit](#) - OATS uses public involvement procedures to select projects for inclusion in the TIP. The three methods used to solicit and gain public input include:

- A public notice;
- Input from an advisory group; and
- The Southwest Missouri Office on Aging.

[The Missouri Department of Transportation](#) – MoDOT SW District, regional planning commissions (RPCs), MPOs, and city and county officials form partnerships to gather and evaluate local input on transportation needs. Public comments concerning transportation needs are gathered from county-wide public meetings, calls to MoDOT's customer service center, public surveys, and comments received by local officials from their constituents. The local officials, generally in conjunction with the RPC and MPO, use these comments in their process for identifying and prioritizing transportation needs in this region. Each RPC and MPO develop a prioritized list of needs for MoDOT's consideration in programming.

The TIP Public Involvement Process

Ahead of the TIP update process and upon completion of the annual STIP prioritization process, the OTO provides notice to the agencies and groups considered interested parties and to agencies that have previously submitted projects to the MPO. The notice

shall include information concerning the transportation issues and processes used in developing a TIP submittal. This notice will provide the information required to propose projects for inclusion in the TIP and the timetable to be followed. The OTO staff will be available to give these agencies and groups any assistance they might require in developing projects for submittal for the TIP.

Agencies submitting projects for inclusion in the TIP will include written documentation of the public involvement procedures used by that agency in selecting projects to include in the TIP and/or for federal funding, e.g., projects for which FTA Section 5307 funding is sought. If written or oral comments that question the need, scope or scheduling of TIP projects or that propose alternative projects are received during the TIP preparation process, the submitting agency will submit a summary analysis report on the disposition of the comments which will be made a part of the approved TIP.

The draft TIP is made available for comment for 30 days prior to Board of Director approval. A legal notice is placed in the *Springfield News-Leader* and/or other community papers. The draft TIP is made available on the OTO website, at the OTO offices, and at the Springfield-Greene County Library, CU Transit office, and the MoDOT SW District office. Any public comment received during this review period will be considered by the OTO staff and will be presented to the Technical Planning Committee and Board of Directors as part of the approval process.

Project sponsors may find it necessary to request revisions to the adopted TIP. TIP amendments and administrative modifications are defined pursuant to 23 CFR § 450.104. TIP Amendments are major revisions which require official approval by the OTO Board of Directors. This is followed by submission to MoDOT for approval by the Governor of Missouri and subsequent approval by the Federal Highway Administration (FHWA) and Federal Transit Administration (FTA).

TIP Amendments require a public comment period of 15 days prior to consideration by the OTO Board of Directors. Notice is announced by press release, Board & TPC agendas, and on the OTO website.

Revisions Requiring TIP Amendments:

1. Addition or deletion of any project (except as noted in the Administrative Modifications section);
2. Substantial changes to the scope of a project (e.g. changing the number of through traffic lanes, changing the type of project such as from rehabilitation to system expansion);
3. Changes in the availability (adding or deleting funds by Congressional action) of earmarked (special appropriation) funds;
4. Moving a project into or out of the first four Federal Fiscal Years of a TIP;
5. Changes in a project's total programmed amount greater than 25% (or any amount greater than \$2,000,000);
6. Changes in a project's fund source(s) from non-Federal to Federal, unless the fund source(s) change from Advanced Construction to an identified Federal funding source; and
7. Changes in the termini of a capacity improvement project of any length OR any project in which the total length changes more than 1/4 mile.

TIP Administrative Modifications are minor revisions which can simply be made by OTO staff after verification that the change(s) falls into this category. More than one administrative modification can be made to a project if meeting the described allowances. Notification of administrative modifications will be provided to the Technical Committee, Board of Directors, MoDOT and Federal Highway Administration (FHWA) and Federal Transit Administration (FTA). TIP Administrative Modifications will require no public comment period. The OTO staff ensures fiscal constraint is maintained.

Revisions Allowed as Administrative Modifications:

1. Changes in a project's total programmed amount less than 25% (up to \$2,000,000);

2. Minor changes to the scope of a project;
3. Minor changes to the termini of a non-capacity project (one that increases or decreases the total length of the project by no more than 1/4 mile);
4. Adding or deleting a project development phase of a project (Environmental Assessment, PE Design, ROW, Construction, or other) without major changes to the scope of the project;
5. Moving funds between development phases of a project (Environmental Assessment, PE Design, ROW, Construction, or other) without major changes to the scope of the project;
6. Moving a project's funds to another fiscal year, provided they are not being moved into or out of the first four fiscal years of the TIP;
7. Minor changes to funding sources between federal funding categories or between state and local sources;
8. Changes in a project's fund source(s) from federal to non-federal with no changes to the project's scope (however, the disposition of the "freed-up" Federal funds remain under the authority of the OTO and are subject to TIP Revisions as appropriate);
9. Changes from Advance Construction to Federal funding or from Federal funding to Advance Construction;
10. Changing a project's lead agency when agreed upon by the two agencies affected;
11. Changes made to an existing project's amount of local or state non-matching funds provided no other funding, scoping or termini changes (beyond what is allowed administratively) are being made to the project;
12. Changes made to an existing project's programmed federal funds, to reflect the actual amount awarded by the federal agency and the corresponding required matching funds (up to 25% or \$2,000,000);
13. Adding a project to the TIP which is split from a "parent project" provided the cumulative total amount of Federal funding in each funding category in the parent and split projects remains intact and the overall scope of work intended to be accomplished does not change (an additional administrative modification may be made to the split project, as allowed elsewhere in this list);

14. Combining two or more projects already in the TIP provided the cumulative, total amount of federal funding in each funding category of the combined projects remains intact and the overall scope of work intended to be accomplished does not change; and
15. Technical corrections.

Unified Planning Work Program

The UPWP is a description of the proposed activities of the OTO for the upcoming fiscal year. The program is prepared annually and serves as a basis for requesting federal planning funds from the USDOT through MoDOT. All tasks are to be completed by OTO staff unless otherwise identified.

The UPWP serves as a management tool for scheduling, budgeting, and monitoring the planning activities of the participating agencies. This document is prepared by OTO staff with assistance from various agencies including MoDOT, FHWA, the FTA, CU Transit, and members of the OTO TPC, which is made up of representatives from each of the nine OTO jurisdictions.

The draft of the new UPWP for the coming year is usually completed by March for TPC review. A 15-day public comment period is required for the UPWP. The UPWP draft document is made available on the OTO website and at the OTO office for public comment. A press release announcing the comment period is sent to media contacts, posted on the OTO website, and posted in full view of the public at the OTO office. An effective means of incorporating public input into the UPWP is to review comments received from the previous year that relate to similar new projects. When developing the work program, the UPWP project manager should take this public comment into consideration.

Public Participation Plan

The PPP provides a framework to guide the public participation process in transportation planning activities at the OTO, such as the UPWP, LRTP, TIP, and a range of programs and special studies, including major investment studies. This plan specifies the OTO's policy

objectives and techniques to be considered and employed in improving the public participation process.

Updates to the PPP itself involve an inclusive public participation process. The process shall meet the goals of the currently adopted Public Participation Plan and strive to employ new and/or underused methods for engaging the public, particularly to evaluate and validate the effectiveness of strategies outlined in the current plan.

Once a final draft of an updated PPP is complete, OTO staff will post it to the OTO website and maintain a hard copy at the OTO office. A press release announcing a 45-day public comment and review period will be sent to media contacts and a legal notice will be placed in the *Springfield News-Leader*. All comments received by the OTO will be considered in the final review by the Board of Directors prior to its adoption.

[Other Plans and Studies](#)

The OTO Transit Coordination Plan (TCP) fulfills the federal requirements of a Human Services Transportation Plan (HSTP) enacted under MAP-21 and the recently adopted FAST Act. The TCP is intended to identify needs and gaps in human service transportation services for seniors and individuals with disabilities in the OTO study area. The TCP is used to guide the use of funds from the Section 5310 Enhanced Mobility for Seniors and Individuals with Disabilities Program.

A draft of the TCP is posted on the OTO website and a paper copy is made available in the OTO office prior to the commencement of a 30-day public comment period. A press release is sent to media contacts providing public notice of the comment period. In addition, a legal notice is placed in the *Springfield News-Leader* and/or other community papers. Figure 1 provides a summary of the public participation process for the OTO's core planning documents.

Several other plans and projects that the OTO develops as needed include, but are not limited to, the [OTO Title VI/ADA program](#), the Annual Listing of Obligated Projects, the

[Limited English Proficiency Plan](#), the Congestion Management Process, and the Performance Measures Report. These other plans and reports require a press release notifying the public of at least a 15-day comment period.

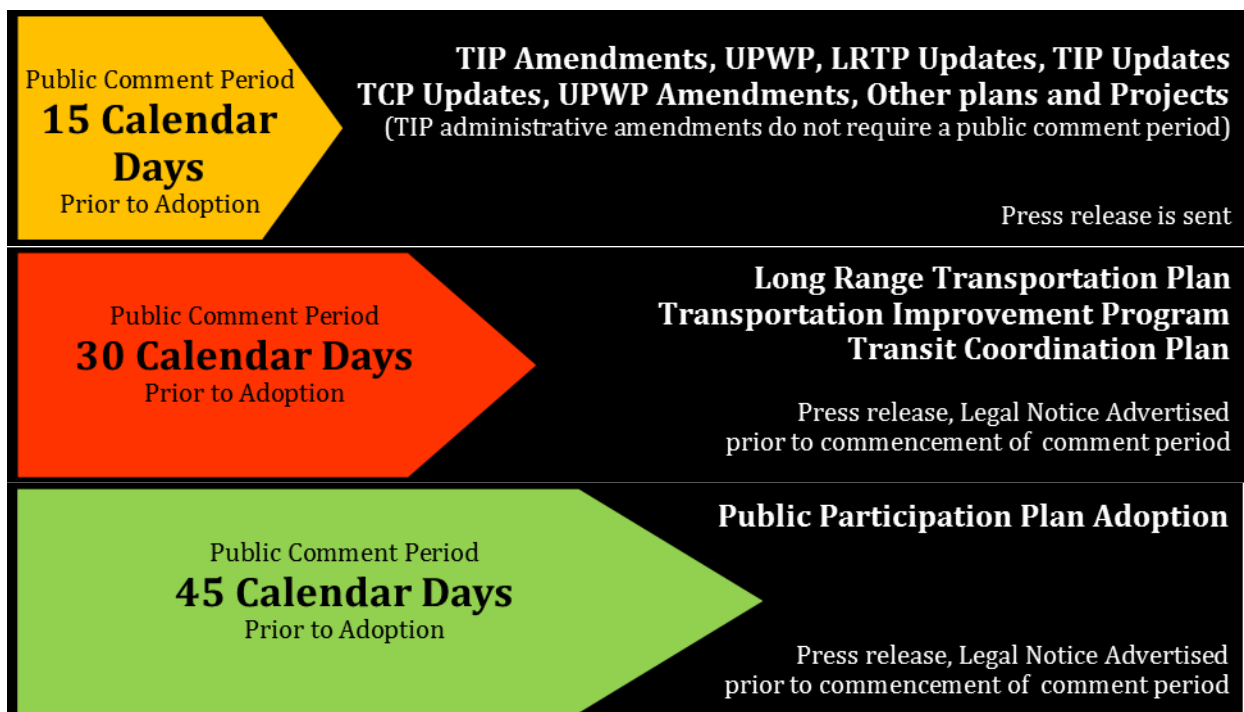

Figure 1 Public Comment Periods for Specific Plans and Purposes

Public Meetings

The [OTO Board of Directors](#) and [Technical Planning Committee](#) meetings are considered public meetings. Other meetings where the OTO leadership conducts business, such as the Executive Committee meetings are also considered public meetings. Press releases are sent to media contacts and agendas are posted in public spaces, including the OTO office, at least one week prior to the meeting date. The body of the press release is posted to the News & Updates section of the OTO website where the public can comment on the content. The URL for the posting is then sent via Facebook and Twitter.

When circumstances arise that prohibit in-person public meetings, such as a public health crisis or other emergencies, the OTO adheres to [Missouri Sunshine Law](#) guidance that provides means for public bodies to conduct public meetings in alternative ways, such as

online meetings or video conferencing. In these instances, the OTO may conduct an “E-meeting” via email where committee members can motion, second, and vote on agenda action items and takes advantage of our website and social media pages to post recordings or live streams of public meetings.

If the OTO chooses to have an online (E-meeting) meeting staff will need to ensure that the meeting notice references the change from the usual method. If the meeting will be held online, “§ 610.020.1, RSMo, requires that the body ‘**post a notice of the meeting on its website in addition to its principal office.**’ Section [610.020.1, RSMo](#), further requires that the body ‘**shall notify the public how to access that meeting.**’” Staff will still need to provide a meeting agenda in the same manner as the standard in-person meeting notice.

The Sunshine Law does not preclude voice-votes during online or video conferencing, however, roll call voting will be conducted for all action items. Generally, under [§610.015, RSMo](#), an elected member of a public governmental body can only participate in a roll call vote if they are physically present or participating via video conferencing. This also means that a quorum of the public governmental body must be present in-person or via video conferencing for a roll call vote to be held.

Public Participation Process

The goal of this outline is to provide structure and continuity for public engagement for various activities of transportation planning conducted by the OTO. The level of public participation required for activities in the planning process changes according to what is to be accomplished. The table below describes a spectrum of participation for an increasing level of public impact. This document provides an outline of the public participation process to be followed for each level of participation on the spectrum.



	Inform	Consult	Collaborate
Type of Plan, Study or Activity	Meeting agendas, Announcements/News, Growth Trends, Studies/Reports, CMP	UPWP, DBE Goals, ALOP, LEPP, Title VI, Amendments	TIP, LRTP, PPP, TCP, Other Studies & Plans
Tools	Press Releases, Social Media, Email, Website	Surveys, Public Meetings, Mailer/postcards, Legal Ads, Blog posts	Workshops, Deliberate Polling, Posters/Flyers, Media Ads, Community Events

Source: Adapted from the International Association for Public Participation "Spectrum of Participation" www.iap2.org.

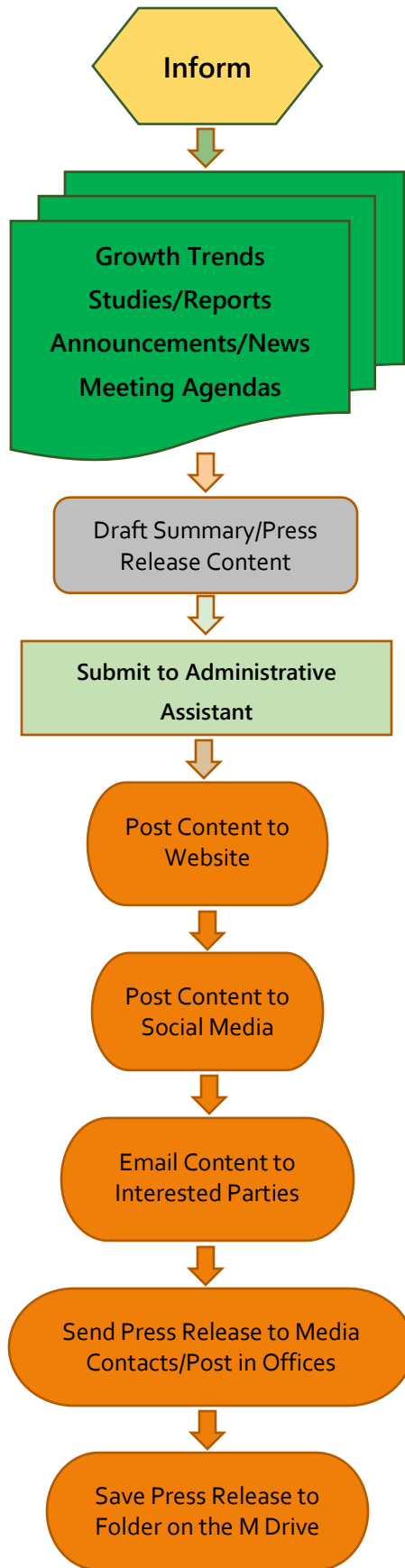

The **inform** level can be a standalone process for **public awareness** and **capacity building**.
 The inform process, however, is also a component of higher levels on the participation spectrum.
 This process will be used to inform the public of surveys, public meetings, and comment periods for plans and studies that require a higher level of public impact.

The lead OTO staff person responsible for the project or task will **prepare a summary or draft press release** with key information for public consumption. The press release/summary will submit information to the communications clerk.

The **administrative assistant** is the position at the OTO that will be responsible for the execution of the process.

All announcements and/or reports will be **posted to the OTO website**, in the OTO office, or other public venues (Library, MoDOT office, etc.).

Summary content will be posted on **Facebook and Twitter** accounts with **links to the content at the OTO website**.

An **email** announcing completion of reports or meeting agendas will be sent to **Interested Parties** if applicable

The **press release** will be emailed to **media contacts** and posted in the OTO offices when applicable.

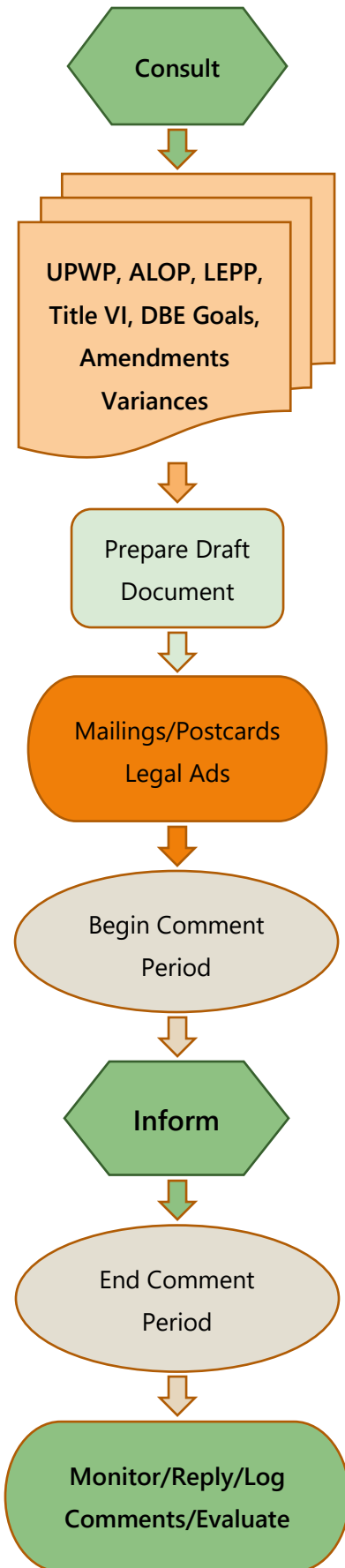

The **consult** level on the participation spectrum includes plans and policies where **public comments are being solicited**.

The consult process **includes** the **inform** process to make the public aware of the how, when, and what regarding the requested feedback.

The UPWP, UPWP Amendments, TIP Amendments have **required comment periods** of specified lengths as per the **Code of Federal Regulations** as presented in the OTO **Public Participation Plan**.

The OTO staff member responsible for the project or task will prepare a **draft document** to be made available **for public comment**.

These tools were not included in the **inform** process. These are **options** to elicit comment from **targeted stakeholder groups** or **document a comment period** which is necessary for some projects in the consult level of participation.

Draft content containing information about **when** the comment period begins and ends, **where** the documents can be accessed, and **how** to comment.

The **inform** process should be initiated as a sub-routine for the consult level of participation. Information should be submitted to the **administrative assistant** for **dissemination**.

At the end of the comment period, all **comments** will be **logged** into a central location and summarized. An explanation of how they impacted the plan or project will be prepared by the OTO staff member responsible for the project or plan and **included as an appendix** to the document.

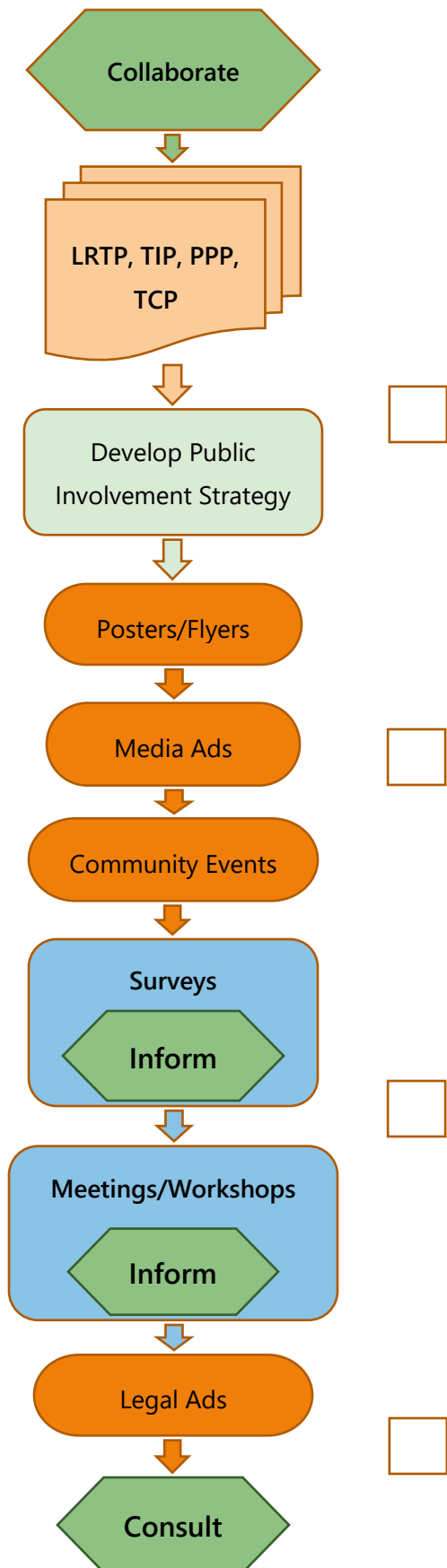

Collaboration is the highest level of participation on the spectrum. This level **includes** both lower participation levels, **inform and consult**. At the collaboration level the **public** is actively **engaged** through **surveys and meetings** to provide **feedback** and **guide** the direction of the plan.

Most of the **plans** and **studies** at the collaboration level **include** the development of a **strategy** for public involvement. If **surveys** are included, they are created with specific content depending on the plan. Information for **meetings and workshops** must be prepared in advance to frame the issues for discussion. The strategy also must include a **“get the word out”** marketing campaign to make the public aware of planning activities.

The **Long-Range Transportation Plan** requires the highest levels of public engagement at the OTO. Public involvement tools that may be included in the strategy for plans and studies at the collaboration level include **direct marketing** with **promotional ads** as well as **posters and flyers** to **create awareness** of planning activities and **build capacity** for participation.

The **inform** process should be initiated for each **meeting, workshop** and/or **survey**. The inform process for these **high-level public involvement mechanisms** can be **enhanced** from its lower level base to include **direct marketing** tools to **“get the word out”** about these opportunities that are **vital** to the collaboration process and **successful plans**.

The **consult** process is initiated **after planning activities** have been completed and a plan document has been drafted to **allow for public comments before plans are adopted** or approved by the BOD. **Legal ads** should be integrated into the process for plans with required comment period lengths set forth in the Code of Federal Regulations as per the PPP.

Appendix A: Interested Party Survey Results

Interested parties were consulted during the preparation of the 2023 Public Participation Plan update via an electronic survey. A link to the survey was sent to 305 email accounts representing interested parties as defined in the Code of Federal Regulations and posted to Facebook and Twitter. The 8-question survey was active from April 8 – April 28, 2023 and resulted in 84 completed surveys.

Question 1: How familiar are you with the Ozarks Transportation Organization and its role in the region?

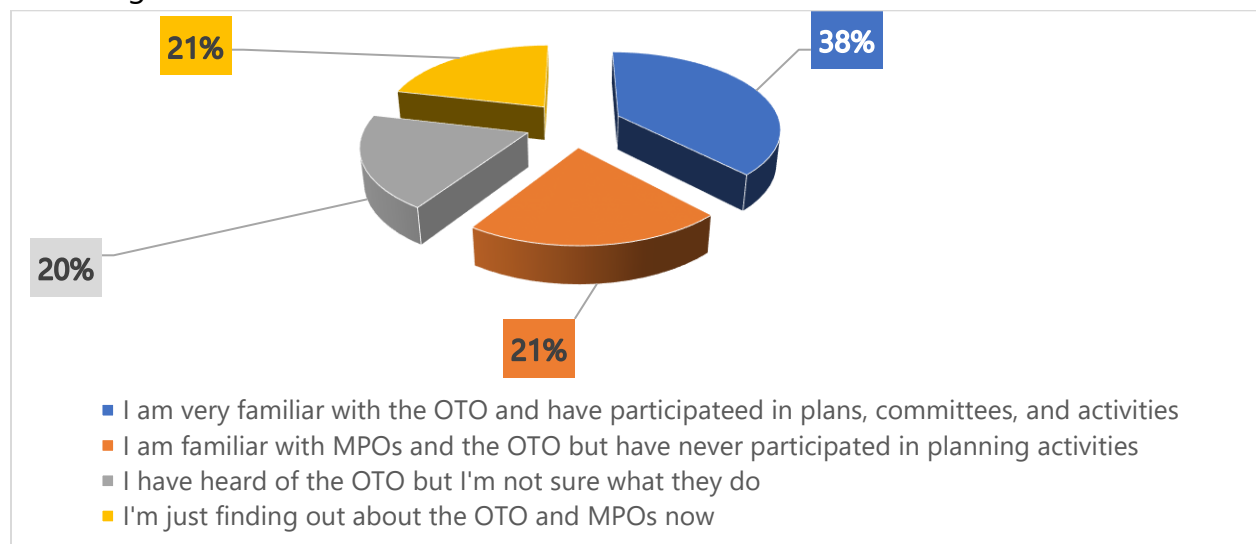

Question 2: Which of these OTO plans or activities are you familiar?

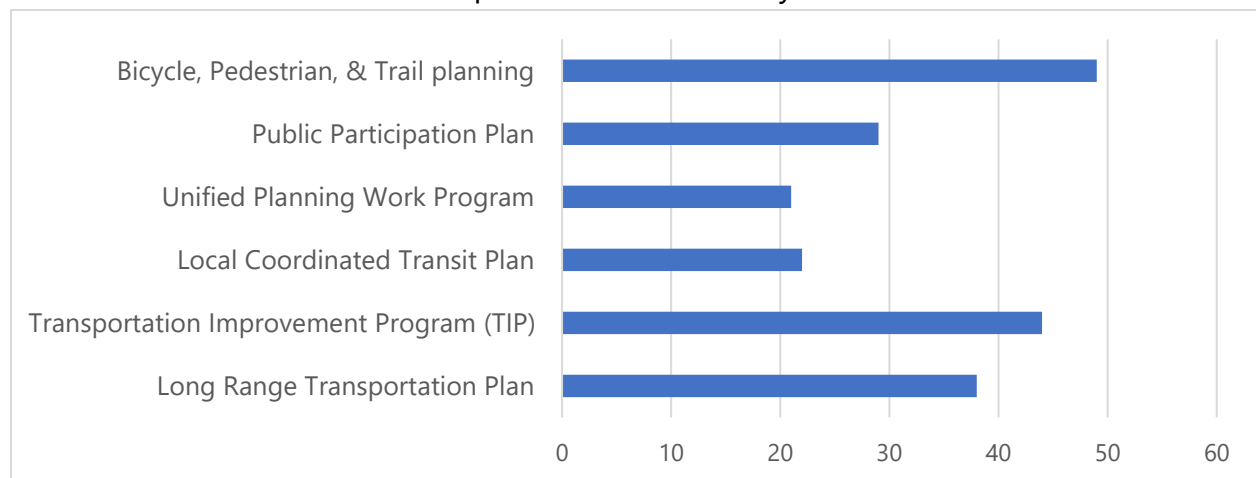

Question 3: Which of the following best describes you?

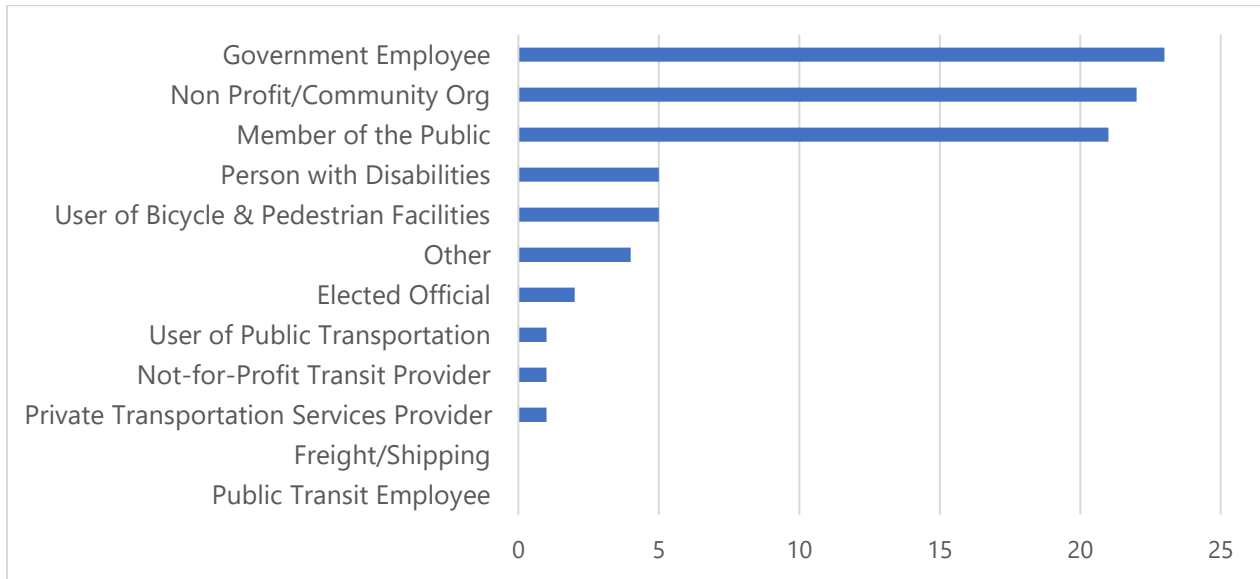

Question 4: Please rank (1 – 8) the following in order of interest

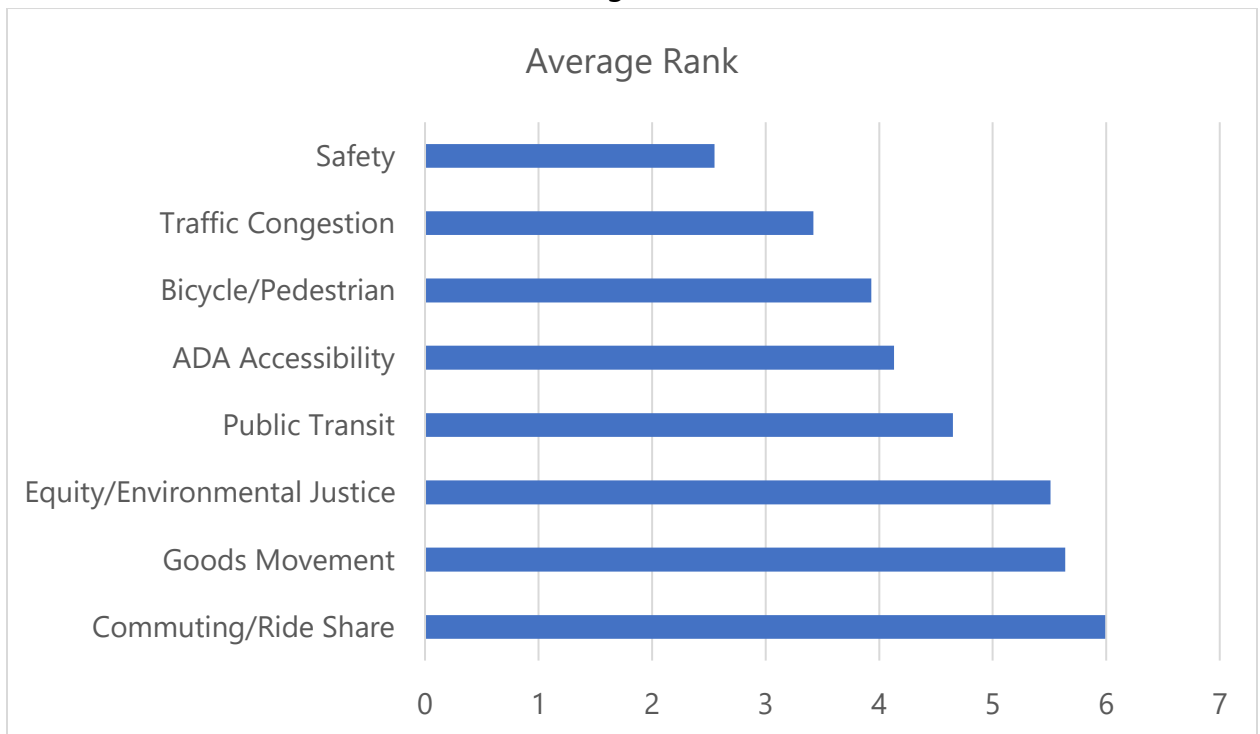

Question 5: How best would you describe your current involvement with the transportation planning process?

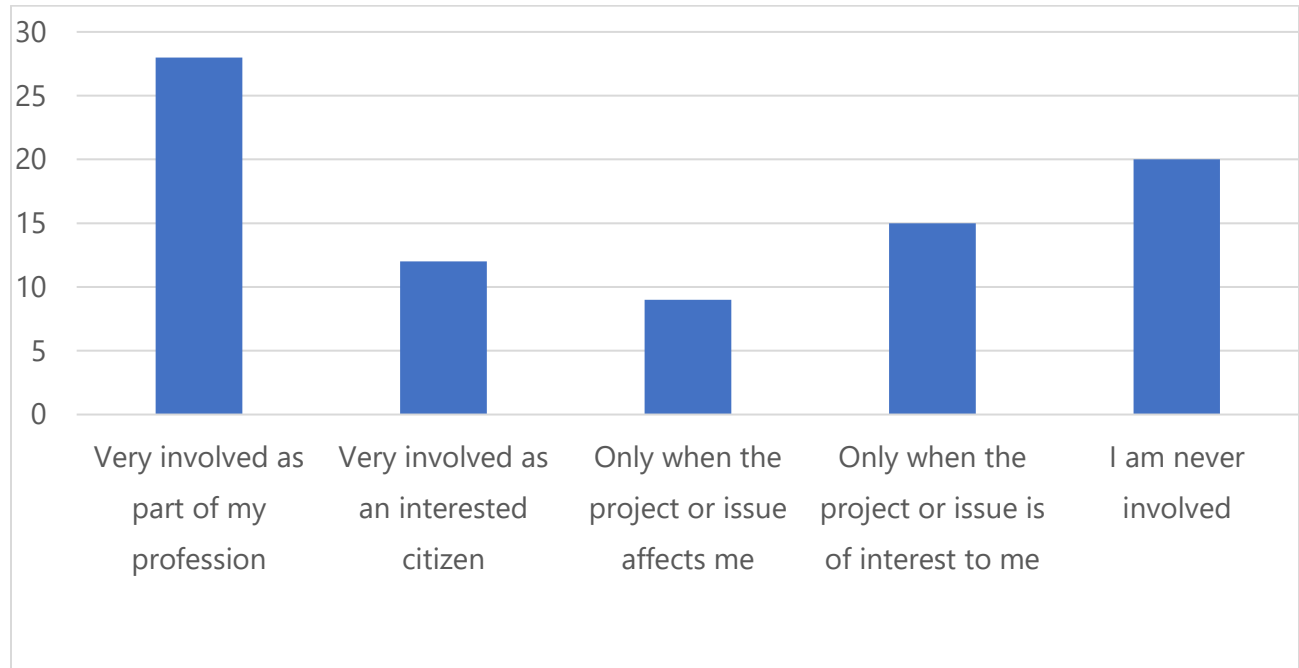

Question 6: What barriers if any prevent you from becoming more involved with the OTO and MPO planning activities?

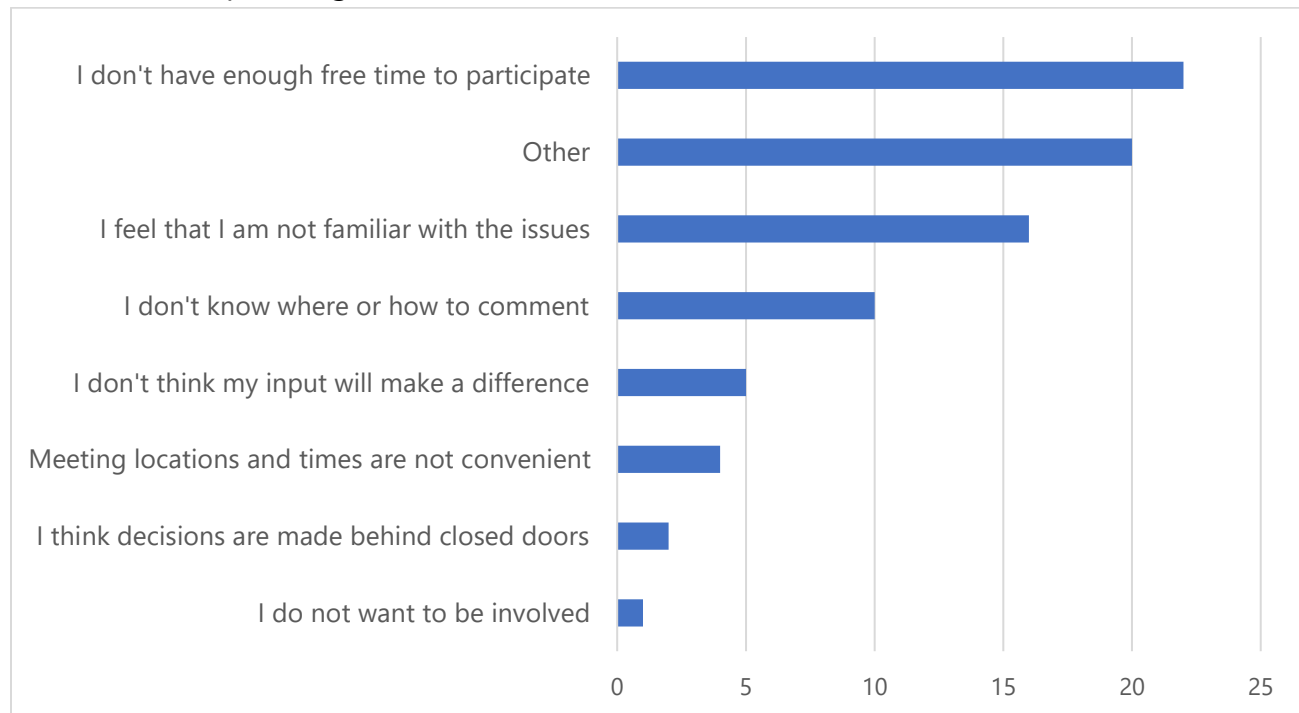

Question 7: How effective are each of the following methods for getting information to you?

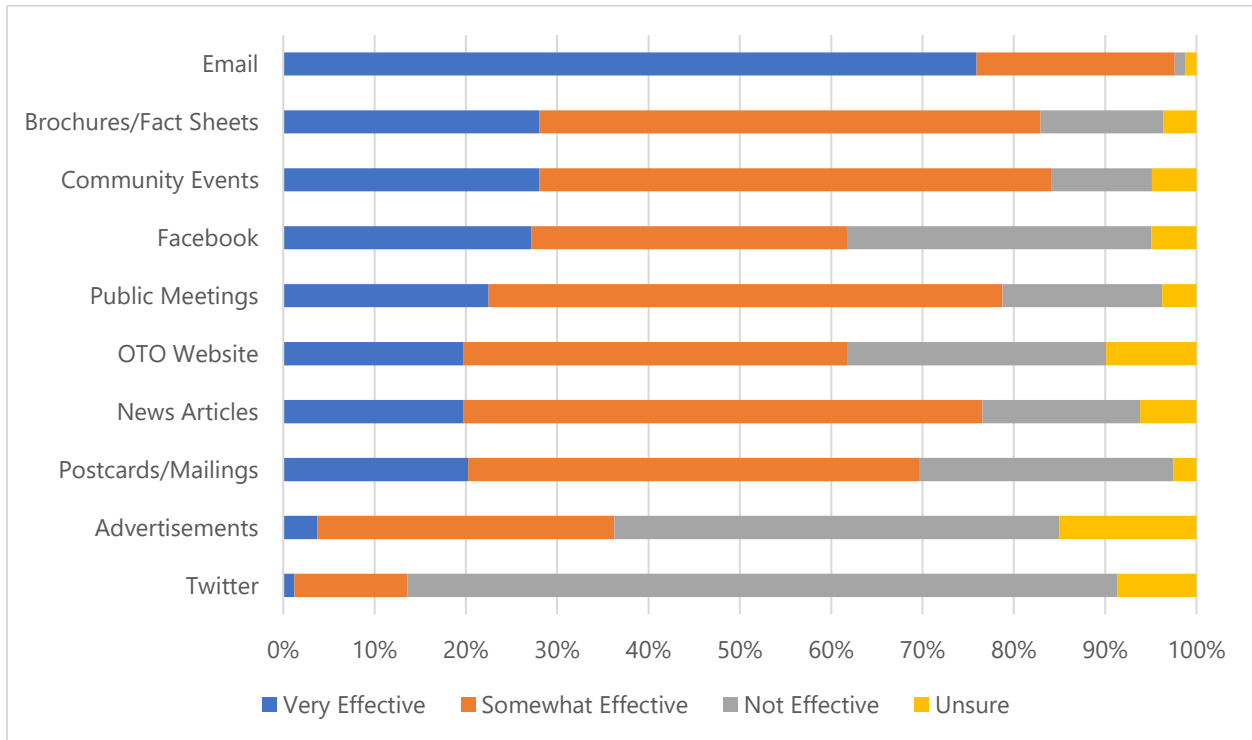

Question 8: How effective are each of these methods for gathering your comments?

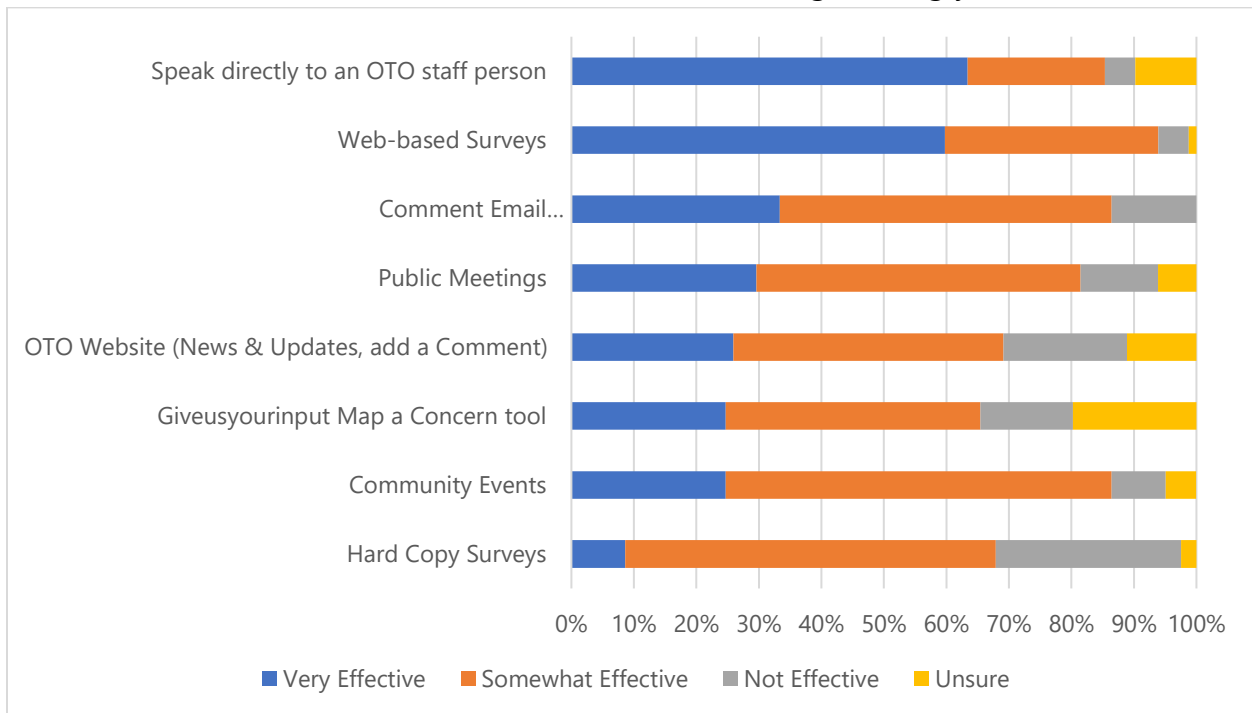

Appendix F: Limited English Proficiency Plan

OZARKS TRANSPORTATION ORGANIZATION

LIMITED ENGLISH PROFICIENCY PLAN

2024



ADOPTED BY BOARD OF DIRECTORS

MAY 16, 2024

Contents

- Introduction 3
 - Background 3
 - The Ozarks Transportation Organization 4
- Four Factor Analysis 5
 - Factor 1: The Number or Proportion of LEP Persons Served or Encountered in the Eligible Service Population 5
 - Factor 2: The Frequency with which LEP Individuals Come into Contact with an MPO Program, Activity, or Service 11
 - Factor 3: The Nature and Importance of the Program, Activity, or Service Provided by the MPO to LEP Community 11
 - Factor 4: The Resources Available to the MPO and Overall Costs 12
- Language Assistance Plan 13
 - Providing Notice of Available Language Service to LEP Persons 13
 - How to Identify an LEP Person who Needs Language Assistance 13
 - Language Assistance Measures 14
 - OTO Staff Training 14
 - Outreach Techniques 14
 - Monitoring and Updating the LEP Plan 15
- Dissemination of the OTO Limited English Proficiency Plan 15
- Appendix-A: Community Groups Serving LEP Populations 16
- Appendix-B: Limited English Proficiency (LEP) Survey 2024 19

This report was prepared in cooperation with the USDOT, including FHWA and FTA, as well as the Missouri Department of Transportation. The opinions, findings, and conclusions expressed in this publication are those of the authors and not necessarily those of the Missouri Highways and Transportation Commission, the Federal Highway Administration, or the Federal Transit Administration.

Introduction

Background

The Ozarks Transportation Organization (OTO) operates its programs and services in accordance with the principle and intentions of the 1964 Civil Rights Act and its implementing acts and guidance. Title VI of the Civil Rights Act of 1964 (42 U.S.C. §2000d et seq) provides that no person in the United States shall, on the grounds of race, color, or national origin, be excluded from participation in, be denied the benefits of, or be otherwise subjected to discrimination under any program or activity receiving federal financial assistance.

On August 11, 2000, Executive Order 13166 was signed into law by President Clinton. This executive order required improved access to service for LEP persons, and gave Title VI (discrimination) protection to LEP persons. Following the Executive Order, the U.S. Department of Transportation (DOT) issued a “Policy Guidance Concerning Recipient’s Responsibilities to Limited English Proficient (LEP) Persons” on December 14, 2005 (Federal Register/ Vol. 70, Mo. 239). DOT’s policy requires DOT recipients to take reasonable steps to ensure meaningful access to their programs and activities by LEP persons. In 2012, the Federal Transit Authority (FTA) released their guidelines and requirements for recipients of FTA financial assistance (FTA C 4702.1). This required MPOs to have an LEP plan, which identifies the LEP populations which might need improved access to the planning process, the methods to identify LEP individuals at public meetings, and identifies available language services.

The FTA also references the DOT LEP guidance in its Circular 4702.1B *Title VI Requirements and Guidelines for Federal Transit Administration Recipients*. Chapter III, Section 9 of this Circular references the LEP requirements and responsibilities and suggests that FTA recipients and subrecipients develop a language implementation plan consistent with the DOT LEP guidance.

The DOT LEP guidance states that “most individuals living in the United States read, write, speak and understand English. There are many individuals, however, for whom English is not their primary language. For instance, based on the 2020 census, regarding individuals older than age 5, over 26 million individuals speak Spanish and almost 7 million individuals speak an Asian or Pacific Island language at home. If these individuals have a limited ability to read, write, speak, or understand English, they are limited English proficient or ‘LEP.’”

The DOT guidance also provides a framework for an analysis on how to determine reasonable steps to ensure meaningful access to recipients’ programs and activities by LEP persons, which includes four factors:

1. The number or proportion of LEP persons eligible to be served or likely to be encountered by the program or grantee;
2. the frequency with which LEP individuals come in contact with the program;
3. the nature and importance of the program, activity, or service provided by the program to people's lives; and
4. the resources available to the grantee/recipient or agency, and costs.

In the LEP plan the OTO incorporates the different policies and guidelines, including the four-factor analysis to ensure meaningful access by LEP persons.

The Ozarks Transportation Organization

The Ozarks Transportation Organization (OTO) MPO is the federally designated regional transportation planning organization that serves as a forum for cooperative transportation decision-making by state and local governments, and regional transportation and planning agencies. MPOs are charged with maintaining and conducting a “continuing, cooperative, and comprehensive” regional transportation planning and project programming process for the MPO’s study area. The study area is defined as the area projected to become urbanized within the next 20 years.

The OTO includes local elected and appointed officials from Christian and Greene Counties, and the cities of Battlefield, Nixa, Ozark, Republic, Springfield, Strafford, and Willard. It also includes technical staffs from the Missouri Department of Transportation, Federal Highway Administration, Federal Transit Administration, and the Federal Aviation Administration.

Staff from local governments and area transportation agencies serve on the OTO’s various committees and provide technical review, comments, and recommendations on draft OTO plans, programs, studies, and issues.

As shown in Figure 1, the LEP study area includes all census tracts that overlap with the OTO boundary due to the availability of the data from the American Community Survey. The LEP study area includes almost all census tracts in Greene and Christian Counties. Each County has one census tract that does not overlap with the OTO boundary. In Christian County, it is census tract 205.02 in the southeast and in Greene County, it is census tract 50.01 in the northwest.

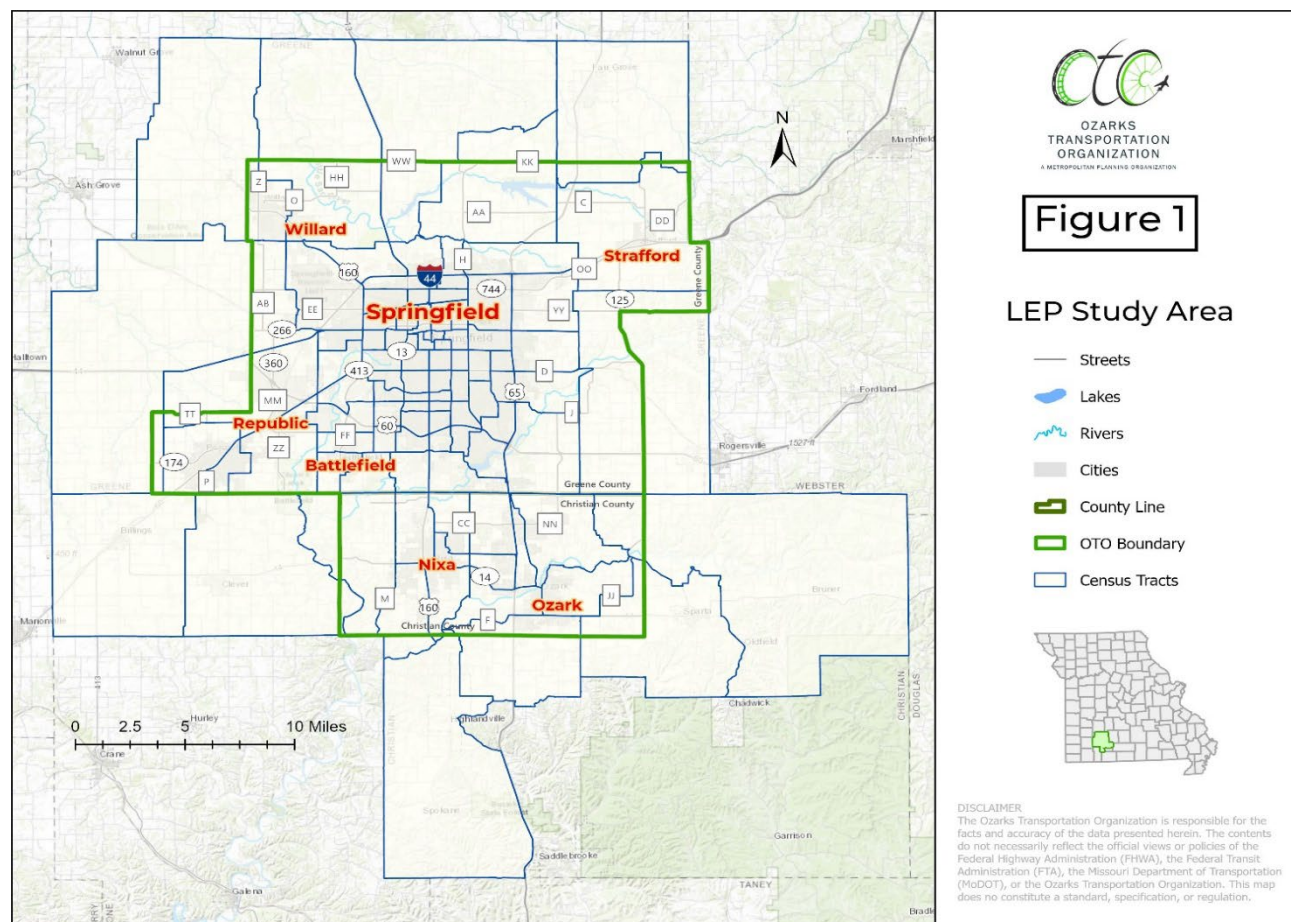

Four Factor Analysis

Factor 1: The Number or Proportion of LEP Persons Served or Encountered in the Eligible Service Population

The first step in determining factors of an LEP Plan is to identify the proportion of LEP persons who may encounter the OTO, their literacy skills in English and their native language, and the location of their communities and neighborhoods within the OTO region.

To do this, the OTO evaluated the level of English literacy and to what degree individuals in the planning area speak a language other than English and what those languages are. This was done by using U.S. Census data from the American Community Survey (Source: U.S. Census Bureau, 2018-2022 American Community Survey 5-Year Estimates Table ID 16001) and data from the Missouri Department of Elementary and Secondary Education. Data has been mapped by census tract, census PUMA, and school district. Please note that the analysis used all census tracts that overlap with the OTO boundary, which increased the population of the LEP study area compared to the OTO service area.

Overall, there are 5,985 individuals that speak English less than “very well,” as shown in Table 1. Greene County has the largest LEP population in terms of overall numbers and percentage of population. The largest group of LEP persons who speak English Less Than “Very Well” speak Spanish, followed by Vietnamese as second largest group. People speaking a language other than English at home in Greene and Christian Counties is much larger than the LEP population. Over 19,100 people live in a home where English is not the dominate language spoken.

TABLE 1 ANALYSIS OF LEP PERSONS

	Greene County Census Tracts that overlap with OTO Study Area	Christian County Census Tracts that overlap with OTO Study Area	All census tracts that overlap OTO Study Area
Number of Persons 5+ Years of Age	278,696	80,610	359,306
Number of Vietnamese Speaking Persons 5+ Years Who Speak English Less Than "Very Well"	338	222	560
Percentage of Vietnamese Speaking Persons 5+ Years Who Speak English Less Than "Very Well"	0.12%	0.28%	0.16%
Number of Spanish Speaking Persons 5+ Years Who Speak English Less Than "Very Well"	1,901	507	2,408
Percentage of Spanish Speaking Persons 5+ Years Who Speak English Less Than "Very Well"	0.68%	0.63%	0.67%
Number of All Persons 5+ Years Who Speak English Less Than "Very Well"	4,729	1,256	5,985
Percentage of All Persons 5+ Years Who Speak English Less Than "Very Well"	1.70%	1.56%	1.67%
Number of Persons 5+ Years of Age that Speak a Language Other Than English at Home	15,769	3,373	19,142
Percentage of Persons 5+ Years of Age that Speak a Language Other Than English at Home	5.66%	4.18%	5.33%

Source: U.S. Census Bureau, 2018-2022 American Community Survey 5-Year Estimates Table, C16001

The OTO also mapped specific Census Tracts where the proportion of LEP persons exceeds the proportion of LEP persons in the service area as a whole. This can be seen in Figure 2 and Figure 3.

These maps highlight those Census Tracts which have a LEP population higher than the MPO average proportion of LEP individuals and Spanish speaking LEP individuals, respectively. Many LEP individuals are in the cities of Springfield, Nixa and east of Republic. The tracts with the highest concentrations of LEP individuals are in central and south-central Springfield, and northern Nixa and between Battlefield and Republic. The census tract with the highest percentage of Spanish speaking individuals, who speak English less than very well is in south Springfield and also includes areas outside the city limits. Other areas of Spanish speaking populations include central Springfield, east of Republic and southern Nixa.

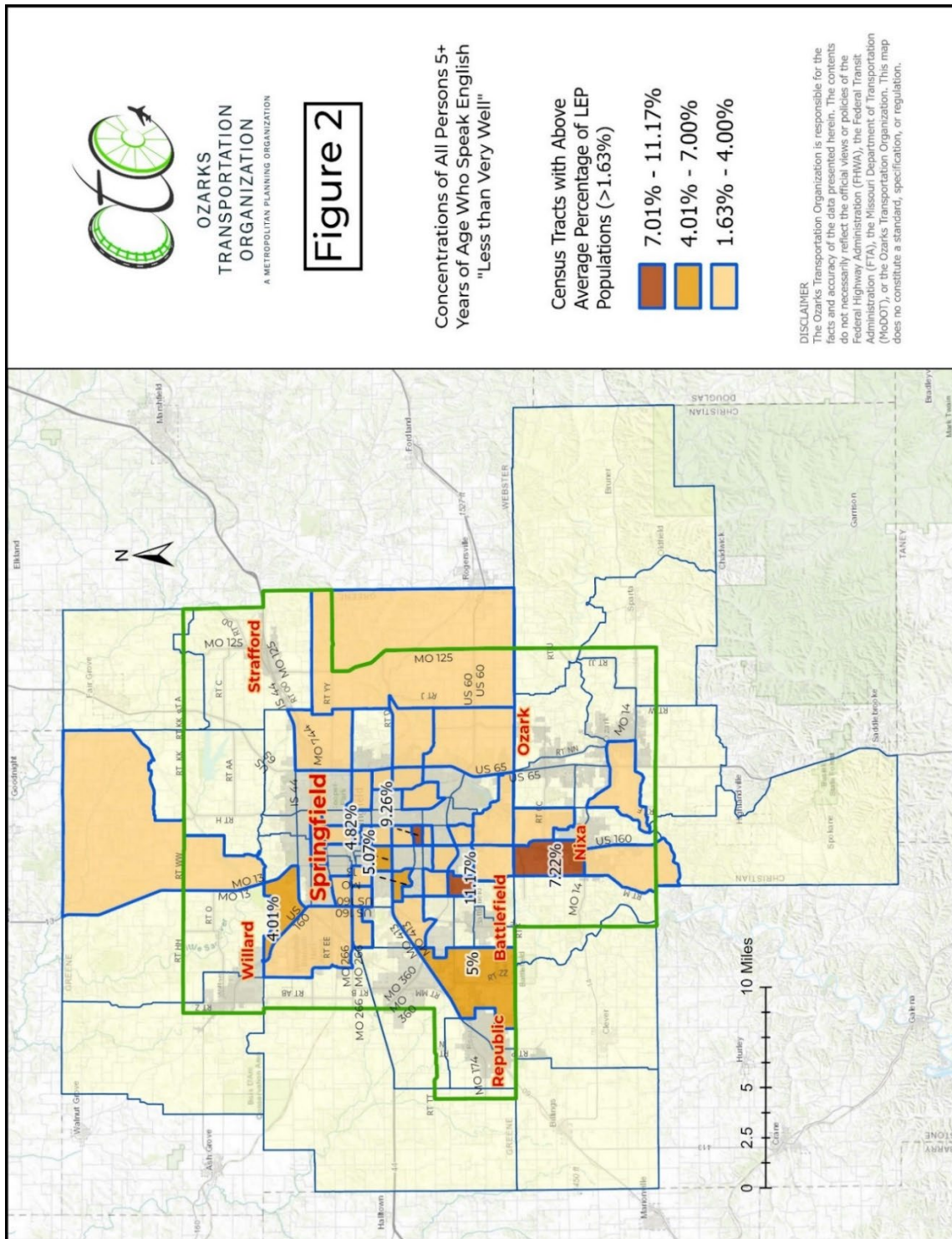



**OZARKS
TRANSPORTATION
ORGANIZATION**
A METROPOLITAN PLANNING ORGANIZATION

Figure 3

Concentrations of Spanish Speaking Persons 5+ Years of Age Who Speak English "Less than Very Well"

Census Tracts with Above Average Percentage of LEP Spanish Speaking Populations (>.66%)

- 4.01% - 9.16%**
- 2.01% - 4.00%**
- 0.66% - 2.00%**

DISCLAIMER
The Ozarks Transportation Organization is responsible for the facts and accuracy of the data presented herein. The contents do not necessarily reflect the official views or policies of the Federal Highway Administration (FHWA), the Federal Transit Administration (FTA), the Missouri Department of Transportation (MoDOT), or the Ozarks Transportation Organization. This map does not constitute a standard, specification, or regulation.

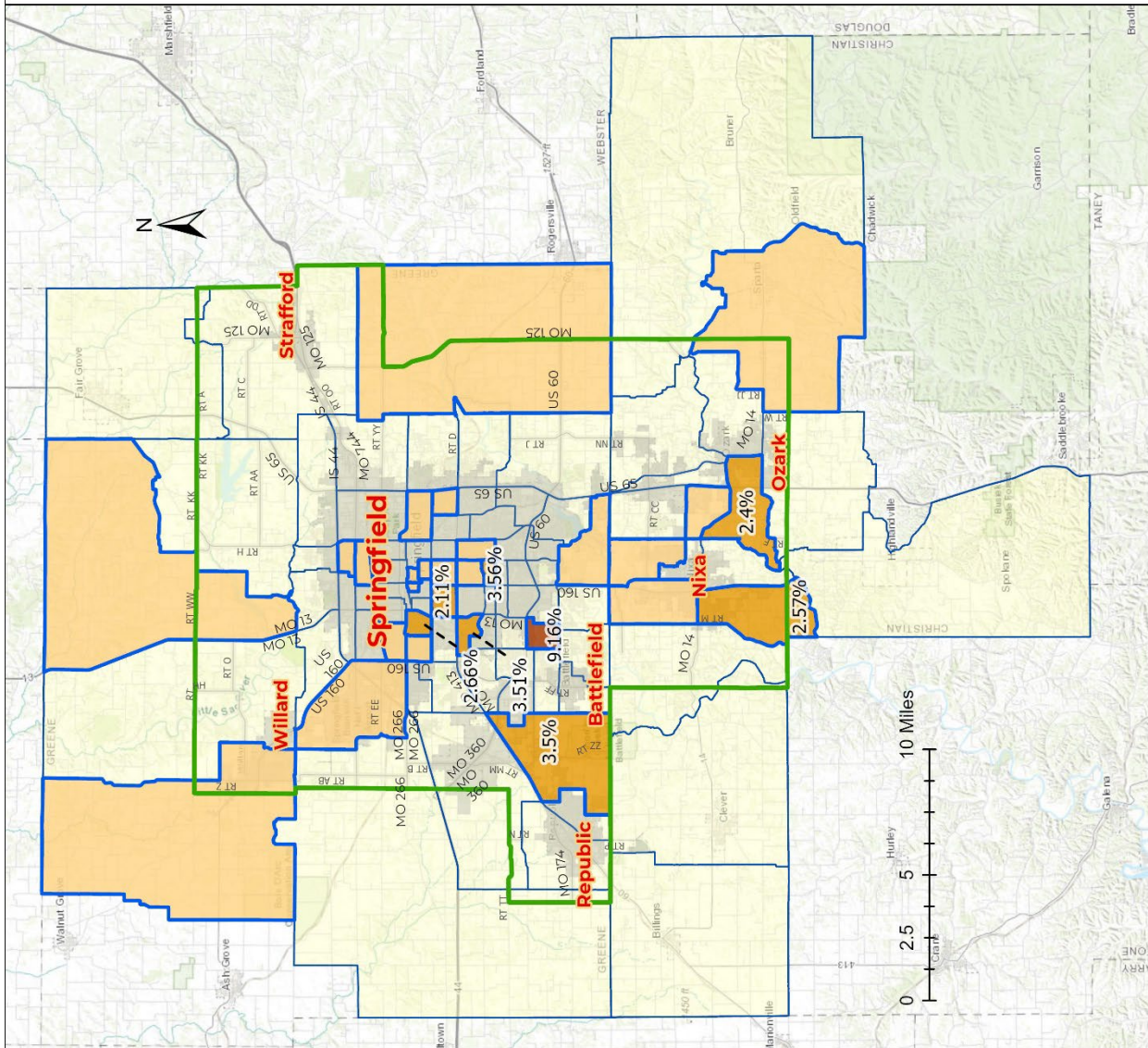

Finally, data on language spoken at home was reviewed. This data is only available for regions with very large populations or for a geographic unit that does not correspond to common jurisdictional boundaries called Public Use Microdata Area (PUMA). PUMAs have similar populations and are designed to protect individual anonymity. The OTO area overlaps with three PUMAs, as shown in Figure 4. The City of Springfield and portions of Greene County immediately surrounding the city are divided into two PUMAs. The remainder of Greene County and all of Christian and Webster Counties are included in a third. Within the two PUMAs containing the City of Springfield, Spanish, Chinese, and Vietnamese are the most common languages other than English spoken at home. Table 2 contains the top ten language groups other than English spoken at home for the two PUMAs containing Springfield combined and individually. Filipino, French, Malayalam, Other English – based Creole languages, and Chin Languages are five languages that appear on the lists for individual PUMAs but not the list for the combined PUMAs.

TABLE 2 TOP 10 LANGUAGE GROUPS OTHER THAN ENGLISH SPOKEN AT HOME, NORTH AND SOUTH SPRINGFIELD PUMAS

Springfield – Combined PUMAs	Individual PUMAs	
	Greene- North Springfield	Greene- South Springfield
Spanish	Spanish	Spanish
Chinese	Vietnamese	Chinese
Vietnamese	Chinese	Russian
Russian	German	Hmong
Hmong	French	Vietnamese
German	Romanian	German
French	Filipino	Tagalog
Romanian	Other English-based Creole languages	French
Tagalog	Telugu	Malayalam
Telugu	Hmong	Chin languages

The third PUMA, including parts of Greene County outside Springfield, Christian County, and Webster County contains information on the large German speaking Amish and Mennonite populations located in Webster County. The German, Swiss German, and Pennsylvania German languages shown in Table 3 primarily correspond with these groups in Webster County. These individuals have limited interaction with the OTO Study Area. The other languages included in this PUMA’s top ten generally correspond to the languages spoken in the two Springfield PUMAs.

TABLE 3 TOP 10 LANGUAGE GROUPS OTHER THAN ENGLISH SPOKEN AT HOME, CHRISTIAN, WEBSTER, AND REMAINDER OF GREENE

Christian, Greene (Outside Springfield), & Webster Counties PUMA
Spanish
Swiss German
German
Romanian
Russian
Hungarian
Pennsylvania German
Japanese
Korean
Tagalog

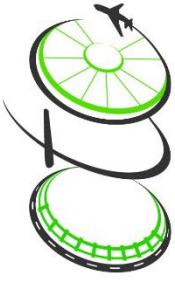

**OZARKS
TRANSPORTATION
ORGANIZATION**
A METROPOLITAN PLANNING ORGANIZATION

Figure 4

**Public Use Microdata Areas
(PUMA) in the OTO Study Area**

- Christian, Greene (Outside Springfield City) & Webster Counties PUMA
- Greene County--Springfield City (North) PUMA
- Greene County--Springfield City (South) PUMA

DISCLAIMER
The Ozarks Transportation Organization is responsible for the facts and accuracy of the data presented herein. The contents do not necessarily reflect the official views or policies of the Federal Highway Administration (FHWA), the Federal Transit Administration (FTA), the Missouri Department of Transportation (MoDOT), or the Ozarks Transportation Organization. This map does not constitute a standard, specification, or regulation.

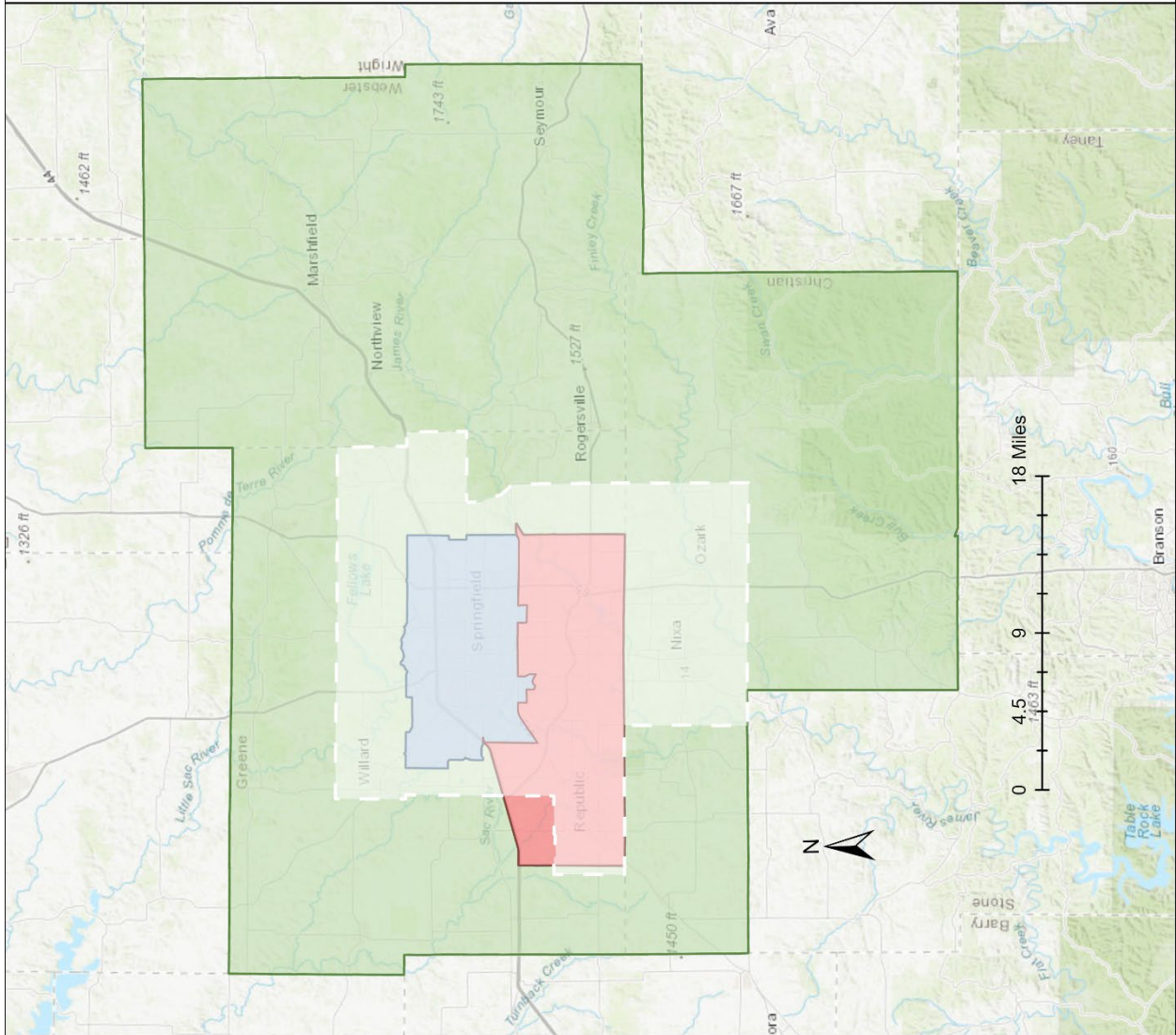

Data from area schools was also consulted to gauge the size of the student English Language Learner (ELL) population in each district, as shown in Figure 5. The Logan Rogersville R-VIII district has the highest percent of ELL students at 5.6%, and Strafford R-VI had the lowest reported percent at 0.67%. While Logan-Rogersville R-VIII has the highest percentage of ELL students, Springfield’s, Nixa’s and Ozark’s actual ELL population is larger than Rogersville’s. All school districts experienced a growth of ELL population since the last analysis with the biggest total increase in the Nixa Public Schools district from 145 to 282 and the lowest increase in the Springfield R-XII district from 1163 to 1168.

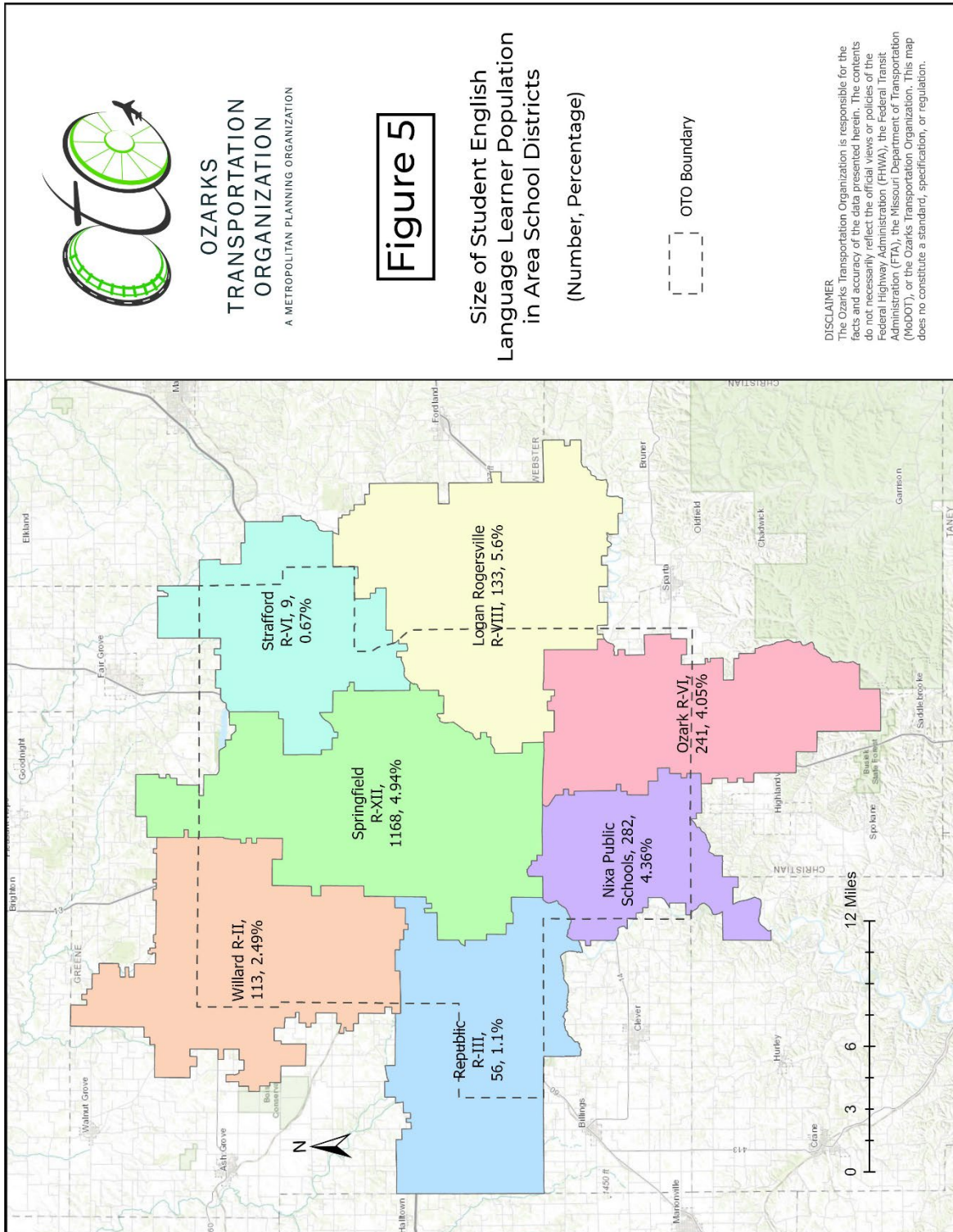

Factor 2: The Frequency with which LEP Individuals Come into Contact with an MPO Program, Activity, or Service

OTO does not have any knowledge, documented or otherwise, of LEP persons coming into contact with an OTO program, activity, or service outside of the 2 individuals who completed City Utilities Transit survey for the ConnectSGF plan in Spanish in 2022. In recent history, there has been no contact at meetings, through Board or Committee members, through phone contact, or by personal visit. Website access by LEP persons is unknown.

City Utilities (CU) Transit System conducted a survey as part of their ConnectSGF study in 2022. ConnectSGF was a planning study to improve the CU transit system with short term and long-term recommendations. The survey was part of the public engagement effort of the study and was conducted in November 2022. The surveys were available online on the City Utilities Transit homepage and were handed out on paper during the Public Visioning Workshop, at the Transit Center during the month and on selected bus routes. A total of 406 surveys were returned. Of the 406 completed, two surveys were completed in Spanish. 4 other individuals completed the survey in English, indicated that they either speak both English and Spanish (2 out of the 4) or just Spanish or Urdu at home. As shown in Table 4, a total of 16 survey respondents indicated they were Hispanic. The survey is a good representation of the overall OTO area as shown in Table 3 of the OTO’s Title VI and ADA program. Please note that the total number of answers to Question 16 is higher than the total number of surveys because respondents could check all race or ethnicities they identify as.

TABLE 4 CITY UTILITIES TRANSIT CONNECTSGF SURVEY

	Total	Percentage
Asian/ Pacific Islander	5	1.2%
Black/ African American	19	4.6%
Latino/ Hispanic	16	3.9%
Native American	16	3.9%
White	339	82.3%
Other	17	4.2%
Total	412	100%

Source: Question 16 of 2022 City Utilities Transit ConnectSGF Survey

Factor 3: The Nature and Importance of the Program, Activity, or Service Provided by the MPO to LEP Community

OTO has three main planning documents which identify and direct OTO’s transportation activities in the region. The Long Range Transportation Plan provides direction for transportation investments twenty years in the future. The Transportation Improvement Program is a schedule of short-range transportation investments and activities intended to be implemented through a combination of State, Federal, and local funding. The Unified Planning Work Program outlines planning tasks and the budget for the upcoming year.

The OTO uses USDOT funds to plan for future transportation projects, and therefore does not include any service or program that requires vital, immediate, or emergency assistance such as medical treatment or services for basic needs (food, housing, education, etc.) or transportation services. The OTO also does not conduct compulsory activities (applications, interviews, or other activities prior to

participation in our programs and/or events). Public involvement with the OTO or its committees is done entirely on a voluntary basis.

The OTO does provide regular opportunities for the public to comment through its bi-monthly Technical Planning Committee and Board of Directors meetings. Input is also sought on the use of Federal funds in major transportation planning areas, including an annual Unified Planning Work Program (UPWP), a 4-year Transportation Improvement Program (TIP), a 5-year Transit Coordination Plan, and a 20-year Long Range Transportation Plan (LRTP). The TIP is updated every year and the Transportation Plan and Transit Coordination Plan every five years. The potential impacts of transportation improvements resulting from these actions may have an impact on all residents and efforts are made to provide an understanding of the process and opportunities to comment.

As a result of this regional transportation planning process, selected projects receive approval for Federal funding and progress toward advanced project planning, design, and construction. Advanced planning, design, and construction usually come under the responsibility of the Missouri Department of Transportation (MoDOT) or a member jurisdiction. These organizations carry-out the coordination with state and federal partners and project area populations. MoDOT and other member jurisdictions have their own policies in place to ensure opportunities for LEP individuals to participate in the process that shapes how and when a specific project is implemented or constructed.

The OTO also completed a survey of regional organizations serving LEP populations to evaluate what services are most critical to the local LEP population and how these groups could be reached best. The survey was sent out via email to organizations where an email address was available and via mail when only a postal address was available in February 2024. The survey was sent out to the 49 organizations shown in Appendix A and completed by eight different organizations, including school districts, universities, churches and one non-profit organization. Appendix B includes the results of the survey.

Survey respondents stated that they work with LEP persons with a wide variety of different languages with Spanish being mentioned the most, followed by Vietnamese and Russian. All these three languages are within the most common languages spoken at home other English in the OTO area as shown in Tables 2 and 3. The survey respondents work with all age groups and the majority stated that they have seen an increase in the LEP population in the last 5 years. The census data in the Factor 1 analysis also shows a total growth of LEP persons from 5,170 in 2019 to 5,985 in 2020. However, the percentage of the total population has seen a slight decrease from 1.75% to 1.67%. Most respondents also stated that most of the LEP persons understand, speak, or write basic English with two respondents noticing that there is a wide spectrum of skills, with some being fluent and others not knowing any English.

The survey identified that the LEP population has expressed an interest or need in public transportation options within the area (See answers to Questions 7 and 8 in Appendix B), but only 2 respondents stated that the LEP population has shown interest in giving input regarding transportation in the area. OTO will strive to increase outreach via the community stakeholders during public participation activities as many respondents stated that these groups or organizations would be trusted contact points.

Factor 4: The Resources Available to the MPO and Overall Costs

The OTO traditionally budgets approximately between \$4,000 and \$4,500 for promotional materials and all general printing costs. As shown in the table below, translation costs associated with major OTO planning documents are between 145% and 176% of budgeted funds. Translation costs would also represent around nine percent of the OTO's operational and commodities budget areas.

Document	Word (approx.)	Avg. Cost per word	Total Cost
L RTP	27,000	\$0.16	\$4,320
TIP	18,000	\$0.16	\$2,880
UPWP	7,600	\$0.16	\$1,216
TCP	9,000	\$0.16	\$1,440
PPP	7,500	\$0.16	\$1,200
Total			\$11,056

Under federal requirements, federal-aid recipients are expected to take reasonable steps to provide language assistance services to its LEP constituents. Notably, reasonable steps do not require a recipient to expend resources for language assistance services if the cost imposed substantially exceeds the benefits. Considering the size of the LEP population in OTO’s MPO area and current financial constraints, full multilanguage translations of large transportation-planning documents and maps is not warranted at this time.

However, OTO meets the safe harbor provision for Spanish speakers that speak English less than very well and that is why OTO will provide the Notice of Rights under Title VI in English and Spanish at the OTO office and on the webpage, as well as the complaint procedures and the complaint form for Title VI and ADA complaints. These documents are seen as vital documents for access to OTO’s program by LEP persons. Further details on language assistance is provided in the next section.

Language Assistance Plan

After analyzing the four factors, OTO developed the plan outlined in the following section for assisting persons of limited English proficiency. This includes identifying what staff and volunteer language interpreters are readily available, which documents should be translated, taking an inventory of available organizations that OTO could partner with for outreach and translation efforts, examining which financial and in-kind sources could be used to provide assistance, and what level of staff training is needed.

Providing Notice of Available Language Service to LEP Persons

- OTO will post public notices for Rights under Title VI in English and in public areas such as the OTO reception area or public notice bulletin board. More detailed materials are also available at the OTO front desk;
- Language identification materials provided by CTS Language Link will also be taken to any off-site meetings hosted by the OTO.

How to Identify an LEP Person who Needs Language Assistance

Below are tools to help identify persons who may need language assistance:

- OTO staff will utilize printed material provided by CTS LanguageLink to identify a spoken language and request an over-the-phone interpreter;
- Examine records requests for language assistance from past meetings and events to anticipate the possible need for assistance at upcoming meetings;
- When OTO sponsored workshops or conferences are held, set up a sign-in sheet table, have a staff member greet and briefly speak to each attendee. To informally gauge the attendee’s

ability to speak and understand English, staff will ask a question that requires a full sentence reply;

- Though language needs may not be met at the current meeting, an inventory of those needs will help staff plan for language needs at a future meeting;
- Post a notice of available language assistance in the OTO reception area.

Language Assistance Measures

Over-the-phone interpretation services are available to OTO staff for walk-in or phone-based interactions with LEP individuals. The OTO currently has a contractual relationship with CTS LanguageLink. This company provides access to interpreters for nearly any spoken language.

Relay Missouri also offers Spanish Relay service for those with hearing impairments. Relay users can type in Spanish and the conversations will be relayed in Spanish. Voice users can speak Spanish to the relay user. Spanish to English Translation is offered. Users must dial 711 or 1-800-520-7309 (TTY/VCO/HCO/STS).

Missouri's Office of Administration also has a list of contractors that supply LEP services including translators, in-person interpreters, phone interpreters, and sign language interpreters. These services are available through the cooperative agreements OTO has with the State of Missouri.

The OTO website may be translated into a number of different languages using Google Translate.

Outside of these measures, OTO has limited resources and will, to the extent possible, ensure LEP individuals can participate when requested.

OTO Staff Training

All OTO staff will be provided with the LEP plan and will be educated on procedures and services available. This information will also be part of the OTO staff orientation process for new hires. Training topics include:

- Understanding the Title VI LEP responsibilities;
- What language assistance the OTO offers;
- How to access an interpreter using CTS LanguageLink;
- Documentation of language assistance requests;
- How to handle a complaint;
- The importance of educating subrecipients on the OTO's LEP program responsibilities and their obligation to provide language assistance.

Outreach Techniques

- If staff knows that they will be presenting a topic that could be of potential importance to an LEP person or if staff will be hosting a meeting or a workshop in a geographic location with a known concentration of LEP persons, staff will have meeting notices, fliers, advertisements, and agendas contain a notice, in Spanish, of language service availability with notification in advance of the meeting.
- When running a general public meeting notice, staff should insert "Si usted necesita la ayuda de un traductor, por favor comuníquese con David Knaut al (417) 865-3047, al menos 48 horas

antes de la reunión,” which asks persons who need Spanish language assistance to make arrangements with OTO within two days of the meeting date.

Monitoring and Updating the LEP Plan

This plan is designed to be flexible and is one that can be easily updated. At a minimum, the OTO will follow the Title VI program update schedule for the LEP plan.

Each update should examine all plan components such as:

- How many LEP persons were encountered?
- Were their needs met?
- What is the current LEP population in the OTO region?
- Has there been a change in the types of languages where translation services are needed?
- Is there still a need for continued language assistance for previously identified OTO programs?
- Are there other programs that should be included?
- Has the OTO’s available resources, such as technology, staff, and financial costs, changed?
- Has the OTO fulfilled the goals of the LEP plan?
- Were there any complaints received?

Dissemination of the OTO Limited English Proficiency Plan

The OTO will post the LEP plan, the compliant procedures, including the public notice and the complaint form on its website at www.ozarkstransportation.org. The complaint procedures and the complaint form will also be posted in English and Spanish.

Any person, including social service, non-profit, and law enforcement agencies and other community partners with internet access will be able to access the plan. For those without personal internet access, all Greene County Libraries offer free internet access. Copies of the LEP plan will be provided to the Missouri Department of Transportation, Federal Highway Administration, the Federal Transit Administration, and any person or agency requesting a copy. Each OTO member will be provided a copy and will be educated on the importance of providing language assistance. An LEP person may obtain copies of the plan upon request.

Any questions or comments regarding this plan should be directed to the OTO Title VI Coordinator.

David Knaut
Ozarks Transportation Organization
2208 W Chesterfield Boulevard, Suite 101
Springfield, MO 65807
Phone: (417) 865-3047 X107
Fax: (417) 862-6013
Email – dknaut@ozarkstransportation.org

Appendix-A: Community Groups Serving LEP Populations

Alliance for Leadership & Success 918 E. Calhoun St Springfield, MO 65802	Asian World Market 2904 S Campbell Ave Springfield, MO 65807	Assembly of God - Chinese Church 1909 W. Chestnut Expressway Springfield, MO 65802
Assemblies of God Southern MO District Headquarters 528 W. Battlefield Springfield, MO 6580	Assembly of God Immanuel Korean Church PO Box 8962 Springfield, MO 65807	Baptist Bible College 628 E. Kearney St. Springfield, MO 65803
Binh Tay Oriental Food 1418 W Sunshine St Springfield, MO 65807	Dol Sem Korean Church 4547 S. Freemont Ave Springfield, MO 65804	Drury University, International Support Services Findlay Student Center 900 N. Benton Ave. Springfield, MO 65802
Ebenezer Romanian Assembly 2233 N. East Ave. Springfield, Mo 65803	El Faro Assembly of God 644 South Eastgate Ave Springfield, MO 65809	Evangel University International Student Services 1111 N. Glenstone Springfield, MO 65802
Filipino Market 3448 S Campbell Ave Springfield, MO 65807	First Korean Presbyterian Church 205 E. South St Nixa, MO 65714	Greene County Baptist Association 834 W. Battlefield Springfield, MO 65807
Grace Romanian Pentecostal Church 2015 W. State Highway WW Springfield, MO 65803	Grupo Latinoamericano 918 E. Calhoun Springfield, MO 65802	Hand in Hand Multicultural Center P.O. Box 1577 Springfield, MO 65801
International Institute Southwest Missouri 1443 N Robberson, Suite 903 Springfield, MO 65802	Iglesia Cristiana Casa De Oracion 3935 W. Sunshine Springfield, MO 65807	Iglesia Rio de Vida 3144 W Grand St Springfield Mo 65802

Islamic Center of Springfield 2151 E. Division Street Springfield, MO 65803	Korean Cumberland Presbyterian Church 416 S. Charleston Ave. Springfield, MO 65804	Latin America Library Services 3728 W. Chestnut Expressway Springfield, MO 65802
Latino Market 1661 E St Louis St Springfield, MO 65802	Life 360 Intercultural Church 1349 W. Meadowmere St. Springfield, MO 65807	Missouri State University English Language Institute 301 S Jefferson Ave Springfield, MO 65806
Nadia's European Market 3023 E. Sunshine St Springfield, MO 65804	New Life Hmong Alliance Church PO Box 474 Brookline, MO 65619	Karen McKnight Nixa Public Schools 301 S Main St. Nixa, MO 65714
Old Town European Market 1257 E Republic Rd Springfield, MO 65804	Our Church of Missouri 1559 S Grant Ave Springfield, MO 65807	Ozark Mountain Deaf Church 776 W. Farm Road 186 Springfield, MO 65810
Dr. Laura Easkins Ozark R-VI School District 302 North 4th Avenue Ozark, MO 65721	Ozarks Technical College International Programs and Services 933 E. Central Springfield, MO 65801	Pathways United Methodist Church 1232 E. Dale Street. Springfield, MO 65803
Beth Trogdon Republic R-III School District 636 N Main Ave Republic, MO 65738	Sacred Heart Catholic Church 1609 N. Summit Ave. Springfield, MO 65803	Second Baptist Church 3111 E. Battlefield Road Springfield, Missouri 65804
Seoul Oriental Market 3165 S Campbell Ave Springfield, MO 65807	Springfield Sister Cities Association 2400 S Scenic Ave Springfield, MO 65807	Slavical Evangelical Church 1005 E. Dale St Springfield, MO 65803
Tatiana Sanchez Springfield Public Schools 1359 E. St. Louis Street Springfield, MO 65802	St. Agnes Catholic Church 533 S. Jefferson Ave. Springfield, MO 65806	Dr. Mark Hedger Strafford R-VI School District 201 W. McCabe Strafford, MO 65757

<p>The Refuge Springfield 3112 W Grand St Springfield, MO 65802</p>	<p>Temple Israel P.O. Box 4284 Springfield, MO 65808</p>	<p>Melissa Lewis Willard R-II School District 500 E. Kime Street Willard, MO 65781</p>
---	--	--

Appendix-B: Limited English Proficiency (LEP) Survey 2024

Limited English Proficiency (LEP) Survey 2024

53

Viewed

11

Total Responses

8

Completed

72.73%

Completion Rate

3

Dropouts

12 min

Average Time

Question 1: To how many LEP persons does your agency provide services on a monthly basis?

Answer	Count	Percent	20%	40%	60%	80%	100%
0-25	0	0%					
26-50	2	25%					
51-75	0	0%					
76-100	0	0%					
100-150	3	37.5%					
150+	3	37.5%					
Total	8	100%					

Question 2: Has the size of the LEP population you serve changed over the last five (5) years?

Answer	Count	Percent	20%	40%	60%	80%	100%
No, it has stayed the same	2	25%					
Yes, it has INCREASED	6	75%					
Yes, it has DECREASED	0	0%					
Total	8	100%					

Question 3: What are the languages spoken by the LEP population you serve?

02/19/2024 63303541 Spanish

02/15/2024 63281748 Arabic, Korean, Chinese, Thai, Taiwanese, Japanese, Mongolian, Vietnamese, Congolese, Spanish, but there have been many more in past years. This is just who we currently have.

- Countries Languages
- Afghanistan Dari and Pashto
- Algeria Arabic
- Argentina Spanish
- Bangladesh Bengali
- Brazil Portuguese
- Bulgaria Bulgarian
- Burundi "Swahili French"
- Colombia Spanish
- Congo "French
- Kituba (indigenous language in Congo)
- Lingala (indigenous language in Congo)
- Swahili and Tshiluba (indigenous language in Congo)"
- Ecuador Spanish
- El Salvador Spanish
- Eritrea Tigrigna
- France French
- Guatemala Spanish
- Haiti Haitian Creole and French
- Honduras Spanish
- India Hindi, English and + 13 more languages
- Iran Persian
- Italy Italian
- Kenya Swahili and English
- Korea Korean
- Mexico Spanish
- Micronesia English, Chuukese and 7 more languages
- Moldova Romanian
- Mongolia Mongolian
- Nicaragua Spanish
- Pakistan Punjabi Pashto - 18.24% Sindhi
- Philippines Tagalog and Cebuano
- Poland Polish
- Puerto Rico English and Spanish
- Russia Russian
- Saudi Arabia Arabic
- Singapore Malay
- South Africa Zulu, Xhosa, and Afrikaans
- Spain Spanish
- Tanzania Swahili
- Thailand Thai
- Ukraine Ukrainian
- United Arab Emirates
- Venezuela Spanish
- Vietnam Vietnamese

02/08/2024 63243571 Spanish

02/02/2024 63201417 Romanian

02/01/2024 63197074 Ukrainian, Russian, Vietnamese, Spanish and many others

02/01/2024 63195800 Chinese, Hungarian, Vietnamese, German, Japanese, Tagalog, Spanish, Portuguese, Burmese, Ukrainian, Russian, and Romanian

02/01/2024 63195187 French, Portuguese (Brazilian), Spanish, Nepalese, Urdu, Pashto, Hindi, Russian, Ukrainian, Polish, Arabic (Egyptian and Levantine dialects), and rare instances of Swahili.

Question 4: What age groups of LEP persons do you serve? (Select all that apply)?

Answer	Count	Percent	20%	40%	60%	80%	100%
Infant/Preschool	4	13.33%	<div style="width: 13.33%;"></div>				
School-Age	6	20%	<div style="width: 20%;"></div>				
18-24	6	20%	<div style="width: 20%;"></div>				
25-35	3	10%	<div style="width: 10%;"></div>				
36-55	4	13.33%	<div style="width: 13.33%;"></div>				
55-65	4	13.33%	<div style="width: 13.33%;"></div>				
65+	3	10%	<div style="width: 10%;"></div>				
Total	30	100 %					

Question 5: Do you serve a roughly equal proportion of males and females?

Answer	Count	Percent	20%	40%	60%	80%	100%
Yes	6	75%	<div style="width: 75%;"></div>				
No, we serve more females than males	0	0%	<div style="width: 0%;"></div>				
No, we serve more males than females	2	25%	<div style="width: 25%;"></div>				
Total	8	100 %					

Question 6: What is the English speaking and writing level of the LEP persons you serve?

Answer	Count	Percent	20%	40%	60%	80%	100%
Most do not speak, understand, read or write English	1	12.5%	<div style="width: 12.5%;"></div>				
Most speak, understand, read and write basic English	2	25%	<div style="width: 25%;"></div>				
Most speak and understand basic English, but have trouble reading or writing in English	2	25%	<div style="width: 25%;"></div>				
Most understand basic English, but have trouble speaking it	1	12.5%	<div style="width: 12.5%;"></div>				
Other:	2	25%	<div style="width: 25%;"></div>				
Total	8	100 %					

Question 6: What is the English speaking and writing level of the LEP persons you serve? - Dynamic Text / Comments

02/15/2024 63281748 [Other:]
We have some who know nothing and others who are very proficient.

02/01/2024 63195800 [Other:]
We have a mixed population with them being pretty equally spread across the spectrum. Some have absolutely not English as they are new the country while we have other that speak it fluently and can read it, but are still working on being proficient in writing (this is the last area for individuals to usually acquire proficiency).

Question 7: What needs or expectations for public services has this population expressed?

02/19/2024	63303541	Buses circulating with more frequency on weekends.
02/15/2024	63281748	They are in great need of public transportation. They could also benefit from driving instruction.
02/13/2024	63264761	Better and more routes around town. More bus stops.
02/08/2024	63243571	More routes
02/01/2024	63197074	Need for adult education English classes and parent transportation to such events to better support their students.
02/01/2024	63195800	Many of those that are new to the country do not have cars or personal modes for transportation so while we having bussing for students, parental involvement on-site is greatly impacted.
02/01/2024	63195187	more frequent bus stops near the campus.

Question 8: Do you feel like the transportation needs of the LEP population you serve, are being meet in the area?

Answer	Count	Percent	20%	40%	60%	80%	100%
Yes	2	25%					
No	6	75%					
Total	8	100%					

Question 8: Do you feel like the transportation needs of the LEP population you serve, are being meet in the area? - Dynamic Text / Comments

02/19/2024	63303541	[No] On Sunday, buses run one every hour. When the weather is cold, there could be long periods of waiting in freezing temperatures at the bus stop.
02/15/2024	63281748	[No] I feel like the bus system is slow and infrequent, but I don't use it, so I'm not sure.
02/13/2024	63264761	[No] Sometimes the closest bus stop is 30'-40' walking distance.
02/08/2024	63243571	[No] Very few routes
02/01/2024	63197074	[No] Parents are in need of transportation to school events or other activities. Many families have 1 car leaving one parent home without transportation to get to school for various events, meetings, etc.
02/01/2024	63195800	[No] Since we are outside of Springfield's city limits, options are more limited and they typically have to rely on others.

Question 9: Has the LEP population you serve shown interest about how to give input regarding transportation in the area, including planning or construction of roadways, bicycle trails, or pedestrian projects, or public transit projects?

02/19/2024	63303541	Posibly
02/15/2024	63281748	no
02/13/2024	63264761	Not really, most of this population are just learning how life in this country works..
02/08/2024	63243571	Not really
02/01/2024	63197074	Not that I am aware of
02/01/2024	63195800	No
02/01/2024	63195187	yes.

Question 10: To what locations in the region does the LEP population you serve travel most frequently?

02/19/2024 63303541 To Latino Market, Supermercado Leslie, and any Walmart. Also, Aldi and second hand stores. For any medical needs they go to Jordan Valley.

02/15/2024 63281748 grocery stores and parks

02/13/2024 63264761 Schools and supermarkets

02/08/2024 63243571 Clinics, churches, the mall

02/02/2024 63201417 To church.
Eben Ezer Romanian Assembly
2233 N East Ave
Springfield, MO 65803

02/01/2024 63197074 Nixa to Springfield businesses or area churches

02/01/2024 63195800 Church, school, grocery store

02/01/2024 63195187 bank, grocery store, airport, shopping mall

Question 11: Are there locations that the LEP population you serve has expressed difficulty accessing via the public transportation system? Accessing via other modes of transportation?

02/19/2024 63303541 They don't have easy access to the Food Bank places in the city.

02/15/2024 63281748 Nearby towns and cities like Branson, KC, and St. Louis. I wish we had a rail system for the larger cities.

02/13/2024 63264761 They are located all around springfield. It's hard to pick a particular location.

02/08/2024 63243571 Don't know

02/01/2024 63197074 There is no public transportation system in Nixa that gets them to Springfield.

02/01/2024 63195800 Getting across HWY 60 in Republic is pretty dangerous and difficult.

02/01/2024 63195187 not that I am aware of

Question 12: What is the best way to obtain input from the LEP population you serve?

02/19/2024 63303541 Maybe by having a survey in Spanish that they can fill out, either on paper or through email.

02/15/2024 63281748 We use Microsoft forms, but google would probably work better.

02/13/2024 63264761 Asking them directly.

02/08/2024 63243571 Facebook

02/01/2024 63197074 Coordination with our EL teachers - they can access the families and receive a response.

02/01/2024 63195800 I would reach out to the local churches that serve these populations (especially Ukrainian/Russian), the International Institute of Southwest MO, and schools can assist.

02/01/2024 63195187 surveys like this.

Question 13: Who would the LEP population you serve trust most in delivering language appropriate messages?

02/19/2024 63303541 A hispanic person that is knowledgeable and friendly.

02/15/2024 63281748 Our director or instructors

02/13/2024 63264761 Anyone willing to listen and has patience.

02/08/2024 63243571 Grupo Latinoamericano

02/01/2024 63197074 EL teachers

02/01/2024 63195800 Schools and churches

02/01/2024 63195187 University administration, Safety and Security personnel, faculty, or possibly local community leaders

Question 15: What geographical area does your agency serve?

02/19/2024 63303541 Springfield in general

02/13/2024 63264761 Green County Springfield, MO

02/08/2024 63243571 Southwest Missouri

02/02/2024 63201417 North Springfield

02/01/2024 63197074 Nixa School District boundaries

02/01/2024 63195800 Parts of Greene and Christian County

02/01/2024 63195187 Southwest Missouri / Springfield

Appendix G: Letter to Owner of Chesterfield Lofts Concerning ADA Issues



June 27, 2017

Mr. Mark Frees
The Wooten Company
1675 East Seminole, Suite B&C
Springfield MO, 6580

Re: ADA Compliance at Chesterfield Lofts

Mr. Frees,

The Ozarks Transportation Organization (OTO) is in the process of evaluating its compliance with the Americans with Disabilities Act of 1990, as amended. We are looking at the accessibility of our programs, our websites, our electronic documents, and our physical office space. In the process of our evaluations, we identified a few accessibility issues with the Chesterfield Lofts Building. We want to bring these issues to your attention, as the Chesterfield Lofts building is subject to Title III of the ADA Act.

Issues identified included numbers of accessible parking spaces, entrance doors closing too fast, restroom doors requiring too much effort to open, and placement of grab bars in the restroom, amongst others. While the configuration of the grab bars match the general configuration outlined in the ADA guidelines, the specific placement does not comply. On the other hand, the doors leading in the building's commercial restroom require approximately 200% more force to open than required in the guidelines. Attached to this letter is a listing of issues identified.

It should be noted the OTO's analysis is not an all-inclusive analysis of the Chesterfield Lofts building, nor is it intended to be authoritative. You are encouraged to evaluate these issues yourself to confirm our measurements and to identify appropriate fixes.



Please let me know if you have any questions regarding our analysis. I can be reached at athomason@ozarkstransportation.org or 865-3047 x107.

Thanks,

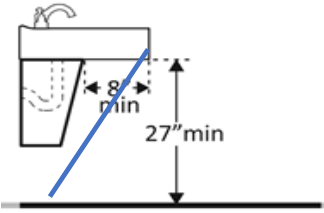
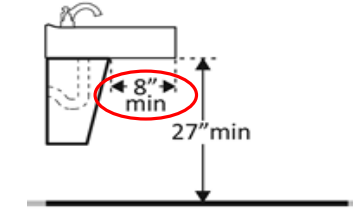
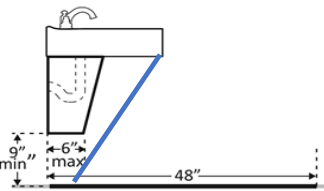
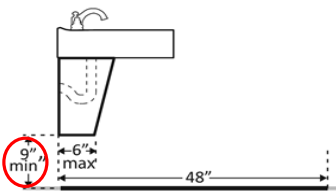
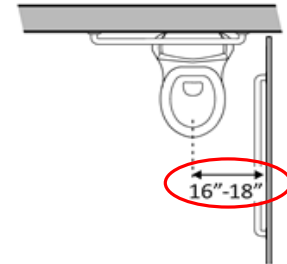
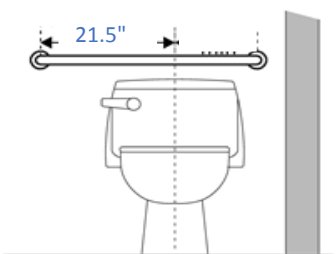

Andy Thomason
ADA Coordinator

Enclosure

Accessibility Issues at Chesterfield Lofts Building 1

Description of Issue	Existing Condition	Requirement
The parking lot behind the Chesterfield Lofts building does not have enough accessible parking spaces	90 Parking Spaces/ 2 Accessible	76-100 Spaces= 4 accessible Spaces
The threshold is too high on front exterior door	11/16" high	1/2" high
The doors on the front exterior entrance, the rear exterior entrance, and the entrance between the lobby and rear vestibule close too quickly	Rear Exterior = 2.7 sec. to close completely Rear Vestibule= 3.2 sec. to close completely Front Exterior= 3.2 sec. to close completely	5 seconds to close within 12 degrees of the latch.
The exterior door to the OTO offices and the door from the lobby close too quickly	Exterior = 3.3 sec. to close completely Lobby = 4.2 sec to close completely	5 seconds to close within 12 degrees of the latch.
Restroom door requires too much force to open	16 lbs to open	5 lbs to open
The lavatory cabinet does not have adequate knee clearance under countertop	 <p>Cabinet shielding plumbing extends to the front of the lavatory countertop</p>	 <p>8" of knee clearance</p>
The lavatory cabinet does not have adequate toe room under the countertop	 <p>The cabinet extends to the floor, 5 inches from wall.</p>	 <p>9" of toe space</p>
The men's toilet is mounted too far from the side wall	The center of the toilet is 20" from the side wall	 <p>16-18" of sidewalk</p>
The grab bar behind the toilet is not mounted in a compliant position	 <p>The bar is only extends 21.5" from the center of the toilet to the open side.</p>	 <p>The bar should extend 24" to the open side of the toilet</p>

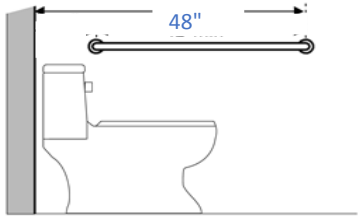
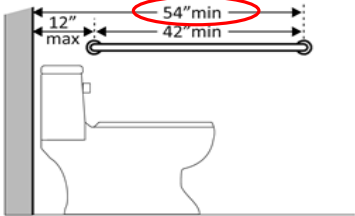
Accessibility Issues at Chesterfield Lofts Building 1

Description of Issue	Existing Condition	Requirement
<p>The grab bar on the side wall does not extend far enough beyond the rear wall</p>	 <p>The bar extends 48" from the rear wall</p>	 <p>The bar should extend 54" from rear wall</p>

Appendix H: Accessible Formatting for Word



ACCESSIBLE FORMATTING FOR MS WORD

Contents

Headings	1
How-To.....	2
Modify Headers.....	2
Object Placement	3
Images	4
How-To.....	4
Notes.....	5
Tables	5
How-To.....	5
Hyperlinks	6
Publishing Accessible Documents	6
Accessibility Checker.....	6
Document Properties.....	7
PDF Settings (Bookmarks).....	7
Publish as HTML.....	8

Headings

All documents need to be organized using headings and subheadings. These elements should be created using MS Word’s Heading Styles. This will ensure screen readers recognize the document’s heading

structure and allow users to navigate the document using these headings. Headings created by independent of MS Word's Style tool will not be recognized.

How-To

MS Word's Styles can be found in the Home Ribbon at the top of the screen, shown in Figure 1. It is important to not skip headings in your document structure (i.e. do not jump from *Heading 1* to *Heading 3*). You can either select a style before you begin typing, or highlight existing text and select a style for that text. Use the *Normal* style for body text. *Heading 1* should be used for the first level heading. Subsequent headings (i.e. *Heading 2*, *Heading 3*) should be used as subheadings. Three levels should be appropriate for most documents.

Modify Headers

Headings can be modified several ways. Characteristics of individual headings may be changed from the Styles section on the Home Ribbon. Characteristics of all the entire heading structure of document theme can be edited on the Design Ribbon.



FIGURE 1 LOCATION OF MS WORD'S HEADING STYLES

Modify Individual Heading Styles

One option is to right-click on the heading style you want to change and click "Modify," see Figure 2. Using this method, you can change size, font, boldness, and other characteristics of the heading.

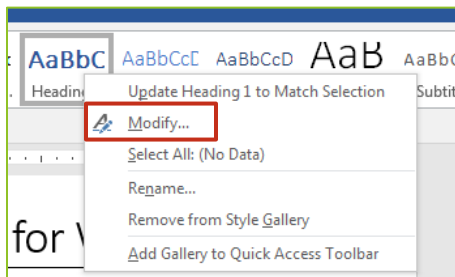

FIGURE 2 MODIFYING INDIVIDUAL HEADINGS

Modify Heading Structure Characteristics

The Design Ribbon contains many predesigned heading structures, see Figure 3. These structures include justification, underlining, and other layout characteristics.



FIGURE 3 PREDESIGNED HEADING STRUCTURES

Once a structure has been chosen, heading themes can be found by clicking on the “Themes” button. Themes primarily include font and color and are common across Office Products.

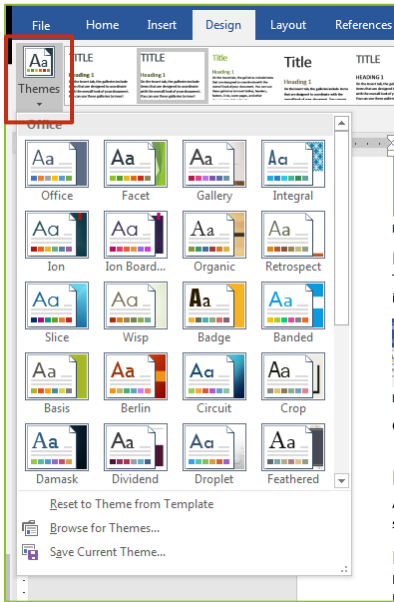

FIGURE 4 HEADING THEMES

[Return to Top](#)

Object Placement

It is important to place any object, whether image, chart, or table, ‘in-line’ with the document’s content. Using features such as text wrapping, in-front of text, or behind text makes the object inaccessible. Screen reading software may skip over these objects or place them in the wrong reading order.

To ensure an object is placed in-line, ensure the *In Line with Text* is selected in the Layout Options. These options can be accessed in multiple ways.

Generally, the layout options can be accessed from the Layout Ribbon. The *Wrap Text* button is in the Arrange portion of the Ribbon, as shown in Figure 5

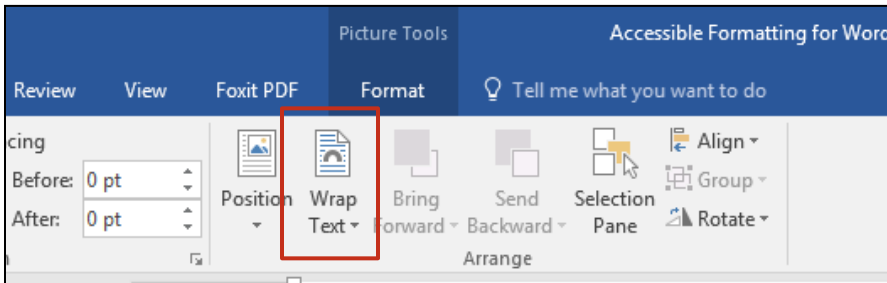

FIGURE 5 LAYOUT OPTIONS ON LAYOUT RIBBON

[Return to Top](#)

For images, click once on the image and then click on Layout button, as shown in Figure 6.

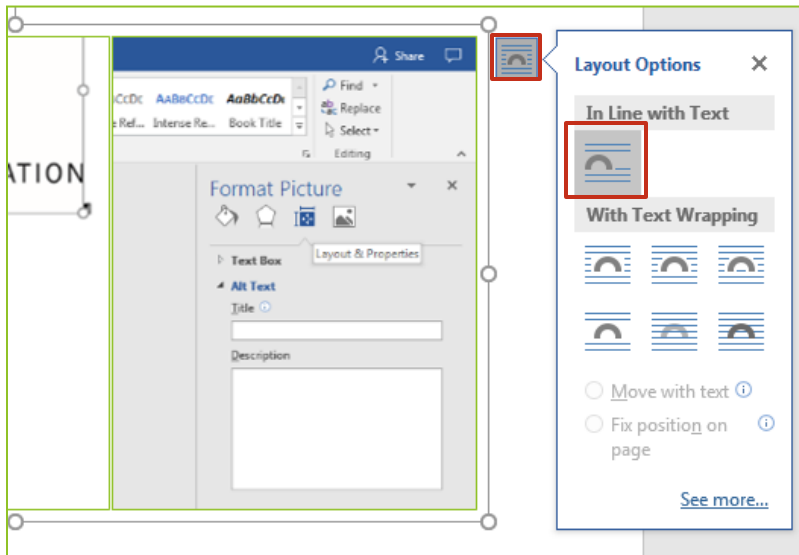

FIGURE 6 LAYOUT OPTIONS FOR IMAGES

If it is not feasible to place an object in-line, use the alternative text to describe how the object relates to the content on that page.

[Return to Top](#)

Images

All images need to have alternative text added. The text describes the content picture and is read by screen reading software. It is important these descriptions be clear and concise.

How-To

Right click on photo and click “Format Picture”. In the “Format Picture” dialogue box, click on Layout & Properties tab. Add a short title and a concise description. Please limit description to 100 words.

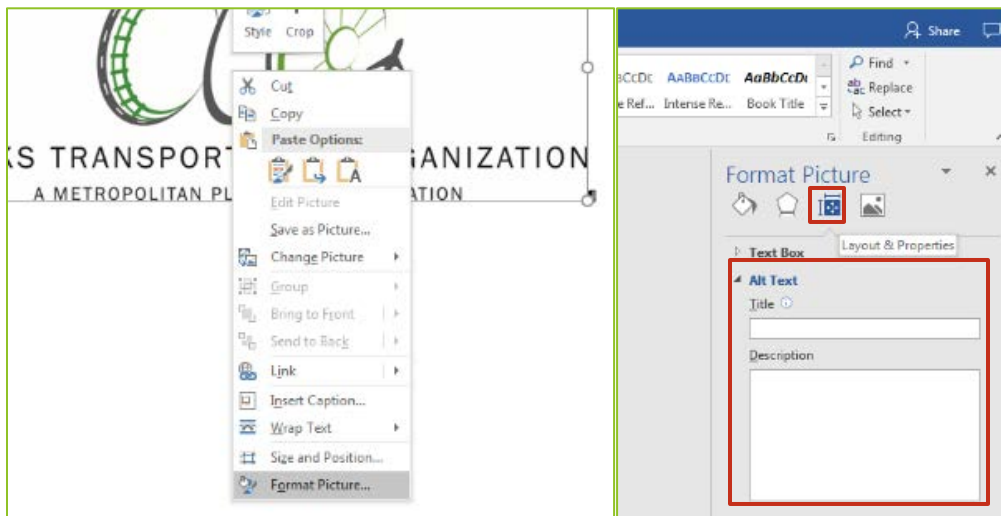

FIGURE 7 HOW TO ADD ALTERNATIVE TEXT

[Return to Top](#)

Notes

If more than one similar image is grouped using MS Word's grouping tool, please use this process to add alternative text to the group.

[Return to Top](#)

Tables

Tables should be kept as simple as possible. If it is necessary to merge and split cells to convey information, a program such as Adobe Acrobat Pro should be used to appropriately tag the table. Regardless of the table's complexity, alternative text should be added to the table. The alternative text should highlight key bits of information contained in the table. Finally, the heading row of the table should be identified using the MS Word's Table Properties function.

How-To

The alternative text option for tables is available through the Table Properties dialogue box. It is important to include key bits of information from the table in the description. Navigate to the Alt Text tab to insert the description, as shown in Figure 8.

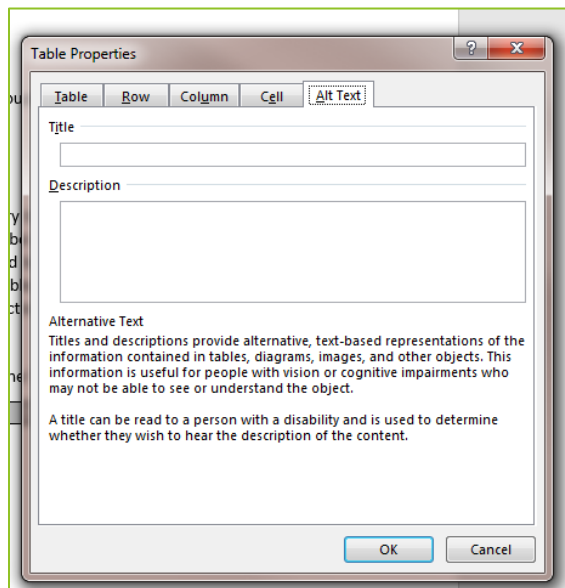

FIGURE 8 ALTERNATIVE TEXT FOR TABLES

[Return to Top](#)

It is important to use MS Word's Table Property to indicate which row in a table is functioning as a header row. First, highlight row that is functioning as header. Then, in the Row tab of the Table Properties dialogue, select 'repeat as header row at the top of each page.'

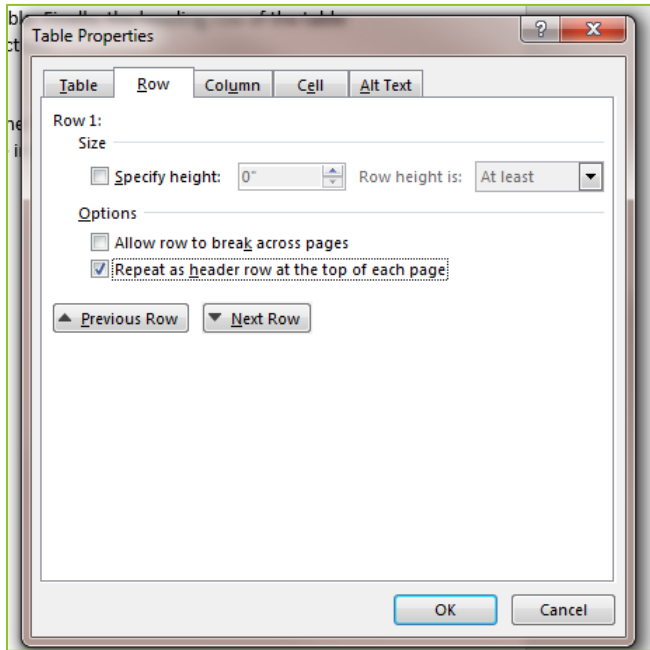

FIGURE 9 HEADER ROW FOR TABLES

[Return to Top](#)

Hyperlinks

Hyperlinks should contain text that describes where the link will take the reader. "Click Here" provides no information about the destination of the link. The text 'TAP Funding Application' would be much more descriptive.

[Return to Top](#)

Publishing Accessible Documents

Accessibility Checker

MS Word has a tool to check accessibility issues with your document. The Tool is available on the Review ribbon as shown in Figure 10. It identifies both critical issues and offers warnings on non-critical issues.

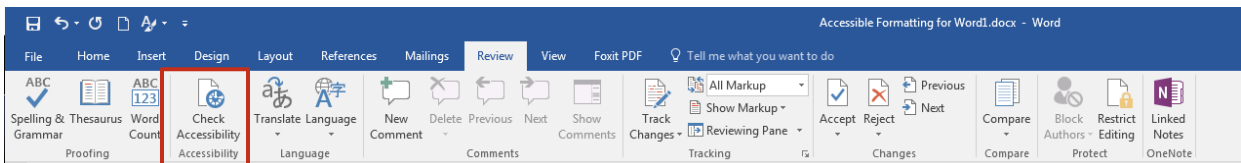

FIGURE 10 ACCESSIBILITY CHECKER

[Return to Top](#)

Document Properties

Before publishing a Word document, complete the summary document properties, including title, subject, and author. These options are available from the File screen, as shown in Figure 11.

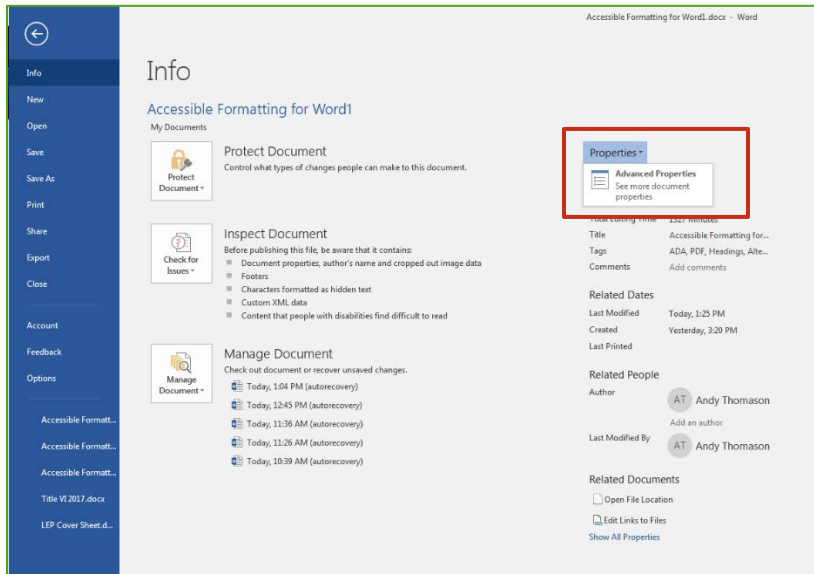

FIGURE 11 ACCESSING DOCUMENT PROPERTIES

The summary properties provide valuable information to all users, not just those using assistive technology.

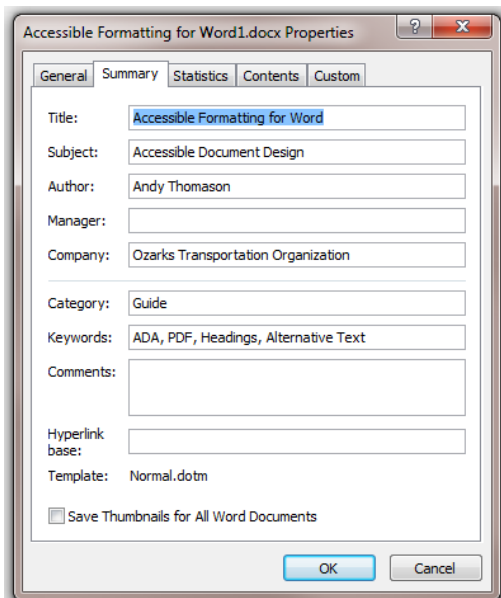

FIGURE 12 DOCUMENT PROPERTIES

PDF Settings (Bookmarks)

It is important to include Bookmarks in the Accessible PDF. MS Word can convert the document's heading structure into bookmarks, if the appropriate option is selected. When Saving as a Word

document as a PDF, click on the “Options” button, as shown in Figure 13. Select the option to create bookmarks using Headings.

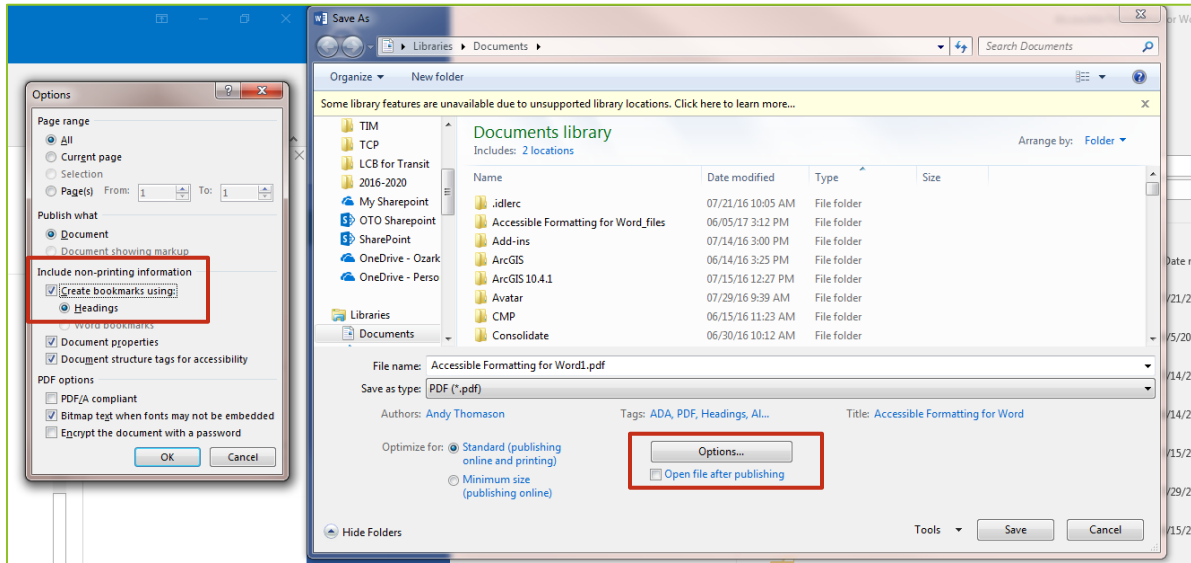

FIGURE 13 PUBLISHING BOOKMARKS

Publish as HTML

Publishing as an HTML file is another accessible option, as shown in Figure 14. HTML is an appropriate alternative format to post online alongside an accessible PDF version.

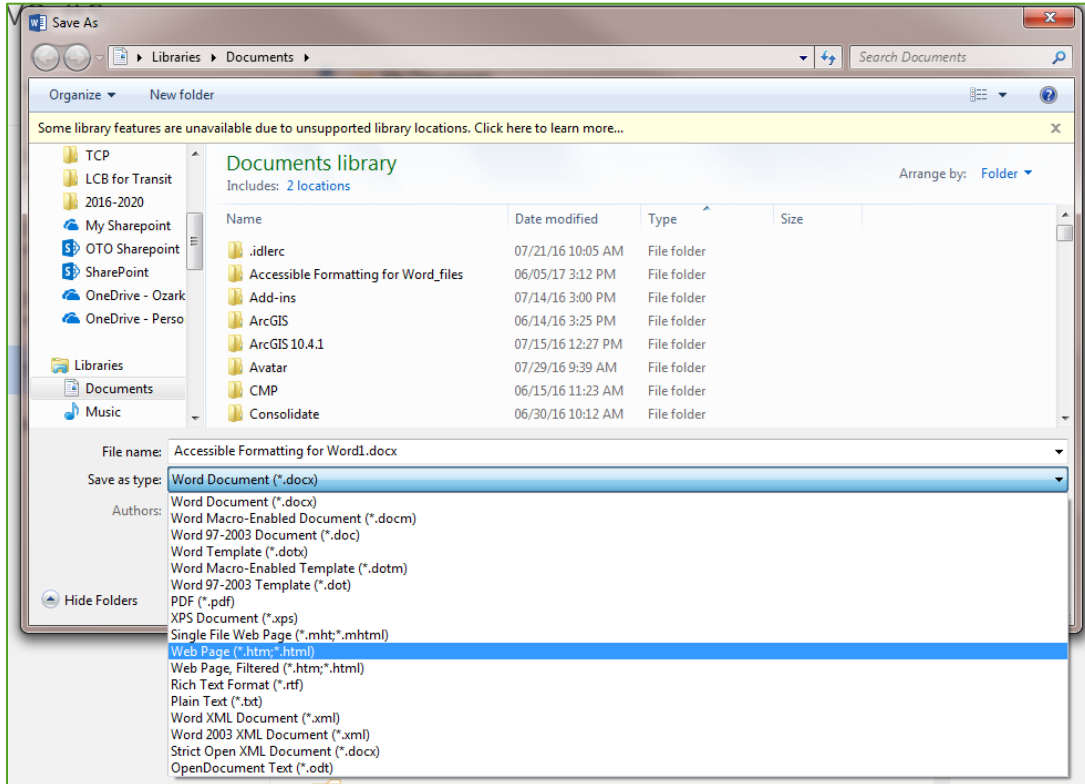

FIGURE 14 SAVING AS HTML

Appendix I: Title VI/ADA/LEP Implementation Guide

Title VI/ADA/LEP Implementation Guide

General Public Notices

Action	Documentation
Title VI/ADA Notice on Public Notices: The standard Title VI notice in English and Spanish shall be included on all press releases, agendas, and other forms of public notice.	<ul style="list-style-type: none"> • Press Release Folder, • Individual Committee Folders
Display of Notice of Title VI Policy: The OTO will always have the Notice of Title VI Policy on Display on the community bulletin board. The notice shall also be display at off-site meeting locations during OTO public meetings/workshops.	<ul style="list-style-type: none"> • Notice on Community Board, • Photo of notice at off-site events

Conducting Public Meetings

Action	Documentation
Initial Verbal Contact: At public meetings, OTO staff will engage each participant in a short conversation. The staff member will be on the lookout for individuals demonstrating limited English proficiency.	<ul style="list-style-type: none"> • New Hire Training Sheet • Annual Training Sheet
Public Transit Access: Offsite meeting locations should be accessible by transit. If multiple meetings are being held to discuss the same topics, at least one location should be accessible by transit.	<ul style="list-style-type: none"> • Annual Offsite Meeting Log
Accessible Meeting Locations: Offsite meeting locations should be ADA accessible. If meetings need to be held in a community with no accessible meeting rooms, meeting packets should be assembled so they can be taken out to citizens unable to access meeting room.	<ul style="list-style-type: none"> • Annual Offsite Meeting Log

Internal Title VI Training

Action	Documentation
New Hire Training: Each new hire will be given a copy of the Title VI/ADA/LEP Resources reference sheet by the Title VI/ADA Coordinator.	<ul style="list-style-type: none">• New Hire Training Completion Sheet (Signed by New Hire)
Annual Training: Each staff member shall complete one civil rights training each year. The Title VI Coordinator shall identify a wide range of webinars that might be of interest to staff members.	<ul style="list-style-type: none">• Annual Training Sheet (Training Topic/Date/Signature or Email)
Title VI Coordinator Training: The Title VI Coordinator will attend a minimum of four hours of civil rights	<ul style="list-style-type: none">• Coordinator Training Log

Appendix J: OTO Title VI/ADA/LEPP Resources

OTO Title VI/ADA/LEPP Resources

Title VI

Title VI/A ADA Program- <https://www.ozarkstransportation.org/uploads/documents/OTO-Title-VI-ADA-Program-2024.pdf>

Description: The Title VI/ADA program describes the OTO's commitment to and policies related to complying with Title VI requirements. It contains analyses, demographic profiles, and assurances.

Complaint Procedures- <https://www.ozarkstransportation.org/uploads/documents/Title-VI-ADA-Policy-and-Complaint-Procedure-2024.pdf>

Description: The Title VI Compliant Procedures outlines the process for filing a Title VI complaint. It contains background information, step-by-step instructions, and contact information for MoDOT and USDOT Civil Rights Offices.

Complaint Form- <https://www.ozarkstransportation.org/uploads/documents/Title-VI-ADA-Complaint-Form.pdf>

Description: The Title VI Complaint form should be completed by anyone wishing to file a Title VI complaint with the OTO. Instructions for completing the Title VI form can be found in the Title VI Complaint Procedures

Limited English Proficient

Limited English Proficient Plan-<https://www.ozarkstransportation.org/uploads/documents/Final-adopted-OTO-LEP-2024.pdf>

Description: This plan identifies the Limited English Proficient Populations the OTO might encounter and how to best engage these populations

Language Link Poster- Front Desk or Title VI Coordinator's Office

Description: These posters have language information from our over-the-phone interpreter.

I Speak Cards- <https://www.lep.gov/resources/ISpeakCards2004.pdf>

Description: "I Speak Cards" are designed to identify the language spoken by an LEP person. Once a person's language is identified, an interpreter can be contacted.

Contact Info Cards- <M:\EMPLOYEE RESOURCES\Civil Rights>ContactInfoCards.pdf> (Internal Resource Link)

Description: These cards are designed to collect contact info and reason for visit from LEP individuals. This will allow us to contact them again once we have identified an appropriate interpreter.

ADA

Title VI/ADA Program- <https://www.ozarkstransportation.org/uploads/documents/OTO-Title-VI-ADA-Program-2024.pdf>

Description: The Title VI/ADA Program describes OTO's effort to comply with ADA and identified actions for improving accessibility.

Formatting Accessible Documents in MSWord- <M:\EMPLOYEE RESOURCES\Civil Rights\Accessible Formatting for Word.pdf> (Internal resource link)

Description: This document can be used by OTO staff to help format accessible documents in MSWord.

Wave Web Accessibility Evaluation Tool- <http://wave.webaim.org/>

Description: This website identifies accessibility issues in any website. The OTO will use this site to internally monitor and improve its websites.